

SUPERPLUS M8-M16

The undercut fixing system that does not require a special setting tool.

FUNCTION

Automatic self-undercutting. The unique design of the SUPERPLUS causes an undercut to be created when the installation torque is applied. The sleeve's outer cutting teeth expand and undercut into the base material. This results in a durable mechanical interlock with base material that functions in both cracked and non-cracked concrete.

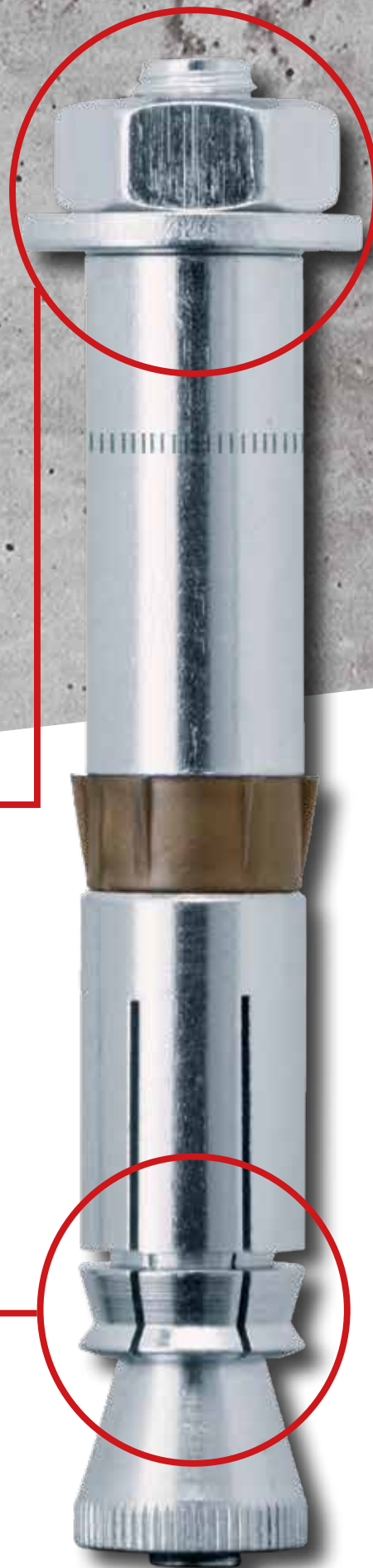

BENEFITS

- High capacity anchor for cracked and non-cracked concrete
- Increased reliability due to undercut technology
- Simple installation, no special drill bit or setting tool required
- Applying torque creates undercut
- Two approved embedment depths per diameter
- Lower installed cost than traditional undercut anchors
- Reduced edge distances and spacings
- Approved for fire resistance
- Custom lengths available on request



European technical approval option1

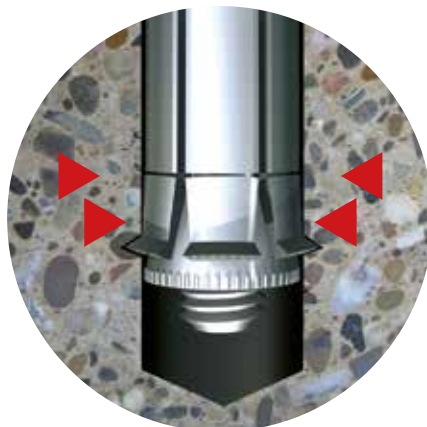

CONSTRUCTION

BLS With hex nut, washer and threaded stud



ILS With internally threaded sleeve



MATERIAL

Grade 8.8 carbon steel, zinc plated
A4-80 stainless steel

BASE MATERIAL

Cracked and non-cracked concrete: C20/25 to C50/60

APPROVAL

ETA-01/0011 – Option 1 – Carbon steel, zinc plated
ETA-05/0013 – Option 1 – A4 stainless steel

LOAD RANGE

Tension: $N_{perm} = 4.3 - 56.1$ [kN]
Shear: $V_{perm} = 4.3 - 90.7$ [kN]

PRODUCT RANGE

BLS: M8, M12 and M16, carbon steel, zinc plated / A4 stainless steel

ILS: M8, carbon steel, zinc plated

APPLICATIONS

- Power plants
- Machines
- Steel and industrial plants
- Façades
- Structural Steel work
- Base plates
- Nuclear

BENEFITS

- High tension and shear capacity
- Reduced edge distances and spacings
- Simple self-undercutting installation
- Two embedment depths per diameter
- No special drill bit or setting tool required
- Shallow embedment depths

PRODUCT DESCRIPTION

The **LIEBIG SUPERPLUS** is available in zinc plated carbon steel and A4 stainless steel. Its design offers the high load capacity and reliability of an undercut anchor, but with the ease of installation of an expansion anchor. In contrast to competing undercut anchor systems, the **SUPERPLUS** does not require special drill bits or setting tools. You need only apply the torque to create the self-undercut.



European technical approval option 1



SUPERPLUS M8-M16

Custom lengths available on request.

SUPERPLUS BLS/BLS-P Carbon Steel Zinc Plated

Threaded stud with hex nut and washer

Material: Grade 8.8 carbon steel, zinc plated

Approval: ETA-01/0011 – Option 1



Type	Order Code	Thread Size	Diameter x Depth of drilled hole	Max Fixture Thickness	Fixture Hole Diameter	Eff. Embedment Depth	Total Length	Weight (kg/100pcs)	Box Quantity
BLS M8-14/40/15	BLS0814040015	M8	14 x 60	15	16	40	80	8.0	25
BLS M8-14/80/25	BLS0814080025	M8	14 x 100	25	16	80	130	13.4	25
BLS M12-20/80/15	BLS1220080015	M12	20 x 105	15	21	80	130	26.5	10
BLS M12-20/80/30	BLS1220080030	M12	20 x 105	30	21	80	145	29.5	10
BLS M12-20/150/30	BLS1220150030	M12	20 x 175	30	21	150	215	43.5	10
BLS M12-20/150/50	BLS1220150050	M12	20 x 175	50	21	150	235	46.0	10
BLS M16-25/150/30	BLS1625150030	M16	25 x 185	30	26	150	220	70.0	10
BLS M16-25/150/40	BLS1625150040	M16	25 x 185	40	26	150	230	72.0	10
BLS M16-25/150/60	BLS1625150060	M16	25 x 185	60	26	150	250	76.0	10
BLS M16-25/200/40	BLS1625200040	M16	25 x 235	40	26	200	280	89.0	10
BLS M16-25/200/60	BLS1625200060	M16	25 x 235	60	26	200	300	95.0	10

*Not included in approval. Available as special order.

SUPERPLUS BLS/BLS-P A4 Stainless Steel

Threaded stud with hex nut and washer

Material: A4-80 stainless steel

Approvals: ETA-05/0013 – Option 1



Type	Order Code	Thread Size	Diameter x Depth of drilled hole	Max Fixture Thickness	Fixture Hole Diameter	Eff. Embedment Depth	Total Length	Weight (kg/100pcs)	Box Quantity
BLS M8-14/80/25A4	BLS0814080025A4	M8	14 x 100	25	16	80	130	13.4	25
BLS M12-20/80/15A4	BLS1220080015A4	M12	20 x 105	15	21	80	130	26.5	10
BLS M12-20/80/30A4	BLS1220080030A4	M12	20 x 105	30	21	80	145	29.5	10
BLS M16-25/150/30A4	BLS1625150030A4	M16	25 x 185	30	26	150	220	70.0	10
BLS M16-25/150/40A4	BLS1625150040A4	M16	25 x 185	40	26	150	230	72.0	10

SUPERPLUS ILS Internally threaded, Carbon steel, zinc plated

Internally threaded sleeve

Material: Grade 8.8 carbon steel, zinc plated



Type	Order Code	Thread Size	Diameter x Depth of drilled hole	Max Fixture Thickness	Fixture Hole Diameter	Eff. Embedment Depth	Total Length	Weight (kg/100pcs)	Box Quantity
ILS M8-14/80	ILS0814080	M8	14 x 100	-	10	80	93	8.7	25

TECHNICAL DATA Carbon Steel Zinc Plated

Permissible loads for single anchors with no influencing edge distances or spacings. Loads are calculated using partial safety factors from ETAG 001 and the characteristic anchor and installation data from this catalogue. Design calculations shall follow the requirements of ETA-01/0011.

Material: Carbon steel, Grade 8.8, zinc plated

Thread Size	M8	M8	M12	M12	M16	M16
Effective embedment depth (h_{ef}) (mm)	40	80	80	150	150	200
Type BLS...	M8-14/40/...	M8-14/80/...	M12-20/80/...	M12-20/150/...	M16-25/150/...	M16-25/200/...

Permissible tension loads¹⁾

N_{perm}		Concrete	[kN]	M8		M12		M16	
				Cracked	Non-Cracked ³⁾	Cracked	Non-Cracked ³⁾	Cracked	Non-Cracked ³⁾
	Cracked Concrete	C20/25	[kN]	4.3	7.6	11.9	19.0	23.8	35.7
		C30/37	[kN]	5.2	9.3	14.5	23.2	29.0	43.6
		C40/50	[kN]	6.0	10.7	16.8	26.9	33.6	50.4
		C50/60	[kN]	6.6	10.8	18.5	28.4	36.9	53.0
	Non-Cracked Concrete ³⁾	C20/25	[kN]	6.1	10.8	17.2	28.4	44.1	53.0
		C30/37	[kN]	7.4	10.8	21.0	28.4	53.0	53.0
		C40/50	[kN]	8.6	10.8	24.3	28.4	53.0	53.0
		C50/60	[kN]	9.4	10.8	26.7	28.4	53.0	53.0

Permissible shear loads^{1) 2)}

V_{perm}		Concrete	[kN]	M8		M12		M16	
				Cracked	Non-Cracked ³⁾	Cracked	Non-Cracked ³⁾	Cracked	Non-Cracked ³⁾
	Cracked Concrete	C20/25	[kN]	4.3	23.7	24.6	40.0	63.0	67.4
		C30/37	[kN]	5.3	23.7	30.0	40.0	67.4	67.4
		C40/50	[kN]	6.1	23.7	34.6	40.0	67.4	67.4
		C50/60	[kN]	6.7	23.7	38.1	40.0	67.4	67.4
	Non-Cracked Concrete ³⁾	C20/25	[kN]	6.1	23.7	34.4	40.0	67.4	67.4
		C30/37	[kN]	7.4	23.7	40.0	40.0	67.4	67.4
		C40/50	[kN]	8.6	23.7	40.0	40.0	67.4	67.4
		C50/60	[kN]	9.4	23.7	40.0	40.0	67.4	67.4

Permissible bending moments^{1) 4)}

M_{perm}	[Nm]	M8	M8	M12	M12	M16	M16
		17.1	17.1	60.0	60.0	152.0	152.0

Spacings, edge distances and member thicknesses

Parameter	Symbol	[mm]	M8	M8	M12	M12	M16	M16
Effective embedment depth	h_{ef}	[mm]	40	80	80	150	150	200
Characteristic spacing ⁵⁾	$s_{cr,N}$	[mm]	120	240	240	450	450	600
Minimum spacing	s_{min}	[mm]	100	80	120	150	200	150
Characteristic edge distance ⁵⁾	$c_{cr,N}$	[mm]	60	120	125	225	225	300
Minimum edge distance	c_{min}	[mm]	80	50	100	80	150	100
Minimum member thickness	h_{min}	[mm]	100	160	160	300	300	400

Installation data

Parameter	Symbol	[mm]	M8	M8	M12	M12	M16	M16
Drill hole diameter	d_0	[mm]	14	14	20	20	25	25
Drill hole depth	h_1	[mm]	60	100	105	175	185	235
Clearance hole in the fixture	Through-fix anchorage	d_f	[mm]	16	16	21	21	26
	Installation on threaded stud	d_f	[mm]	10	18	14	14	18
Width across flats	sw	[mm]	17	17	22	22	27	
Installation torque	T_{inst}	[Nm]	25	25	80	80	180	

Installed anchor

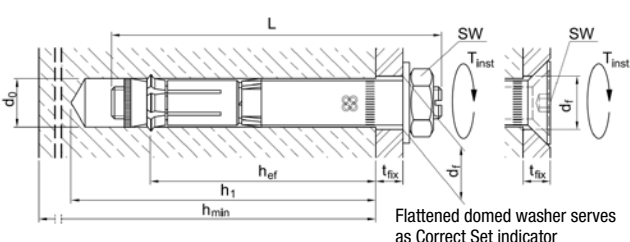

1) The permissible loads have been calculated using the partial safety factors for resistances stated in the ETA-approval and a partial safety factor for actions of $\gamma_F = 1.4$. The permissible loads are valid for unreinforced concrete and reinforced concrete with a rebar spacing $s \geq 15$ cm and reinforced concrete with a rebar spacing $s \geq 10$ cm if the rebar is 10 mm or smaller.

2) The permissible shear loads are based on a single anchor without influencing concrete edges. For shear loads applied close to an edge ($c \leq 10 h_{ef}$ or $60 d$) concrete edge failure must be checked per ETAG 001, Annex C, design method A.

3) Concrete is considered non-cracked when the tensile stress within the concrete is $\sigma_t + \sigma_a \leq 0$. In the absence of detailed verification $\sigma_t = 3$ N/mm² can be assumed (σ_t equals the tensile stress within the concrete as a result of external loads, forces on anchors included).

4) The permissible bending moments are only valid for the threaded stud (e.g. in case of a distance mounting).

5) If spacings or edge distances become smaller than the characteristic values (i.e. $s \leq s_{cr,N}$ and/or $c \leq c_{cr,N}$) a calculation per ETAG 001, Annex C, design method A must be performed.

For details, see ETA-01/0011.

TECHNICAL DATA A4 Stainless Steel

Permissible loads for single anchors with no influencing edge distances or spacings. Loads are calculated using partial safety factors from ETAG 001 and the characteristic anchor and installation data from this catalogue. Design calculations shall follow the requirements of ETA-05/0013.

Material: A4-80 stainless steel

Thread Size	M8	M8	M12	M12	M16	M16
Effective embedment depth (h_{ef}) (mm)	40	80	80	150	150	200
Type BLS...	M8-14/40/...	M8-14/80/...	M12-20/80/...	M12-20/150/...	M16-25/150/...	M16-25/200/...

Permissible tension loads¹⁾

N_{perm}	Concrete	Concrete Class	[kN]	M8		M12		M16	
				Cracked	Non-Cracked ³⁾	Cracked	Non-Cracked ³⁾	Cracked	Non-Cracked ³⁾
	Cracked Concrete	C20/25 [kN]	4.3	5.7	11.9	19.0	23.8	28.6	
		C30/37 [kN]	5.2	7.0	14.5	23.2	34.9	34.9	
		C40/50 [kN]	6.0	8.1	16.8	26.9	40.3	40.3	
		C50/60 [kN]	6.6	8.9	18.5	29.5	44.3	44.3	
	Non-Cracked Concrete ³⁾	C20/25 [kN]	6.1	13.1	17.2	30.1	44.1	56.1	
		C30/37 [kN]	7.4	13.1	21.0	30.1	53.8	56.1	
		C40/50 [kN]	8.6	13.1	24.3	30.1	56.1	56.1	
		C50/60 [kN]	9.4	13.1	26.7	30.1	56.1	56.1	

Permissible shear loads^{1) 2)}

V_{perm}	Concrete	Concrete Class	[kN]	M8		M12		M16	
				Cracked	Non-Cracked ³⁾	Cracked	Non-Cracked ³⁾	Cracked	Non-Cracked ³⁾
	Cracked Concrete	C20/25 [kN]	4.3	24.0	24.6	48.5	63.0	90.7	
		C30/37 [kN]	5.3	24.0	30.0	48.5	76.8	90.7	
		C40/50 [kN]	6.1	24.0	34.6	48.5	88.8	90.7	
		C50/60 [kN]	6.7	24.0	38.1	48.5	90.7	90.7	
	Non-Cracked Concrete ³⁾	C20/25 [kN]	6.1	24.0	34.4	48.5	88.2	90.7	
		C30/37 [kN]	7.4	24.0	42.0	48.5	90.7	90.7	
		C40/50 [kN]	8.6	24.0	48.5	48.5	90.7	90.7	
		C50/60 [kN]	9.4	24.0	48.5	48.5	90.7	90.7	

Permissible bending moments^{1) 4)}

M_{perm}	[Nm]	M8	M8	M12	M12	M16	M16
		16.1	16.1	56.4	56.4	142.9	142.9

Spacings, edge distances and member thicknesses

Parameter	Symbol	Unit	M8	M8	M12	M12	M16	M16
Effective embedment depth	h_{ef}	[mm]	40	80	80	150	150	200
Characteristic spacing ⁵⁾	$s_{cr,N}$	[mm]	120	240	240	450	450	600
Minimum spacing	s_{min}	[mm]	100	80	150	150	150	180
Characteristic edge distance ⁵⁾	$c_{cr,N}$	[mm]	60	120	120	225	225	300
Minimum edge distance	c_{min}	[mm]	60	50	100	80	100	100
Minimum member thickness	h_{min}	[mm]	100	160	160	300	300	400

Installation data

Parameter	Symbol	Unit	M8	M8	M12	M12	M16	M16
Drill hole diameter	d_0	[mm]	14	14	20	20	25	25
Drill hole depth	h_1	[mm]	60	100	105	175	185	235
Clearance hole in the fixture	Through-fix anchorage	d_f	16	16	21	21	26	26
	Installation on threaded stud	d_f	10	10	14	14	18	18
Width across flats	sw	[mm]	17	17	22	22	27	27
Installation torque	T_{inst}	[Nm]	25	25	80	80	180	180

Installed anchor

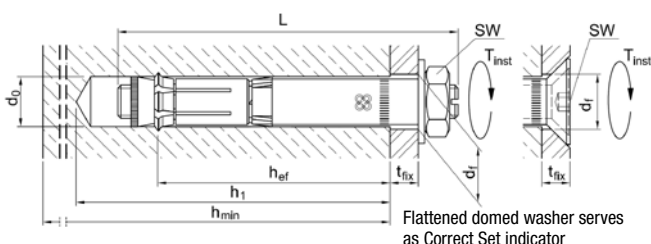

1) The permissible loads have been calculated using the partial safety factors for resistances stated in the ETA-approval and a partial safety factor for actions of $\gamma_F = 1.4$. The permissible loads are valid for unreinforced concrete and reinforced concrete with a rebar spacing $s \geq 15$ cm and reinforced concrete with a rebar spacing $s \geq 10$ cm if the rebar is 10 mm or smaller.

2) The permissible shear loads are based on a single anchor without influencing concrete edges. For shear loads applied close to an edge ($c \leq 10 h_{ef}$ or $60 d$) concrete edge failure must be checked per ETAG 001, Annex C, design method A.

3) Concrete is considered non-cracked when the tensile stress within the concrete is $\sigma_t + \sigma_c \leq 0$. In the absence of detailed verification $\sigma_c = 3 \text{ N/mm}^2$ can be assumed (σ_t equals the tensile stress within the concrete as a result of external loads, forces on anchors included).

4) The permissible bending moments are only valid for the threaded stud (e.g. in case of a distance mounting).

5) If spacings or edge distances become smaller than the characteristic values (i.e. $s \leq s_{cr,N}$ and/or $c \leq c_{cr,N}$) a calculation per ETAG 001, Annex C, design method A must be performed.

For details, see ETA-05/0013.

TECHNICAL DATA Internally threaded anchor, Carbon steel, zinc plated

Permissible loads for single anchors with no influencing edge distances or spacings. Loads are calculated using partial safety factors from ETAG 001 and the characteristic anchor and installation data from this catalogue.

Material: Carbon steel, zinc plated

Thread Size	M8
Effective embedment depth (h_{ef}) (mm)	80
Type ILS...	M8-14/80/...

Permissible tension loads¹⁾

N_{perm}	Cracked Concrete	C20/25	[kN]	7.6
		C30/37	[kN]	9.3
		C40/50	[kN]	10.7
		C50/60	[kN]	10.8
	Non-Cracked Concrete ³⁾	C20/25	[kN]	10.8
C30/37		[kN]	10.8	
C40/50		[kN]	10.8	
C50/60		[kN]	10.8	

Permissible shear loads^{1) 2)}

V_{perm}	Cracked Concrete	C20/25	[kN]	8.4
		C30/37	[kN]	8.4
		C40/50	[kN]	8.4
		C50/60	[kN]	8.4
	Non-Cracked Concrete ³⁾	C20/25	[kN]	8.4
C30/37		[kN]	8.4	
C40/50		[kN]	8.4	
C50/60		[kN]	8.4	

Spacings, edge distances and member thicknesses

Effective embedment depth	h_{ef}	[mm]	80
Characteristic spacing ⁴⁾	$s_{cr,N}$	[mm]	240
Minimum spacing	s_{min}	[mm]	80
Characteristic edge distance ⁴⁾	$c_{cr,N}$	[mm]	120
Minimum edge distance	c_{min}	[mm]	50
Minimum member thickness	h_{min}	[mm]	160

Installation data

Drill hole diameter	d_0	[mm]	14
Drill hole depth	h_1	[mm]	100
Clearance hole in the fixture	d_f	[mm]	10
Threaded depth	L_e	[mm]	12 to 23
Hexagon socket depth	T_i	[mm]	4
Width across flats	sw	[mm]	8
Installation torque	T_{inst}	[Nm]	25

Installed anchor

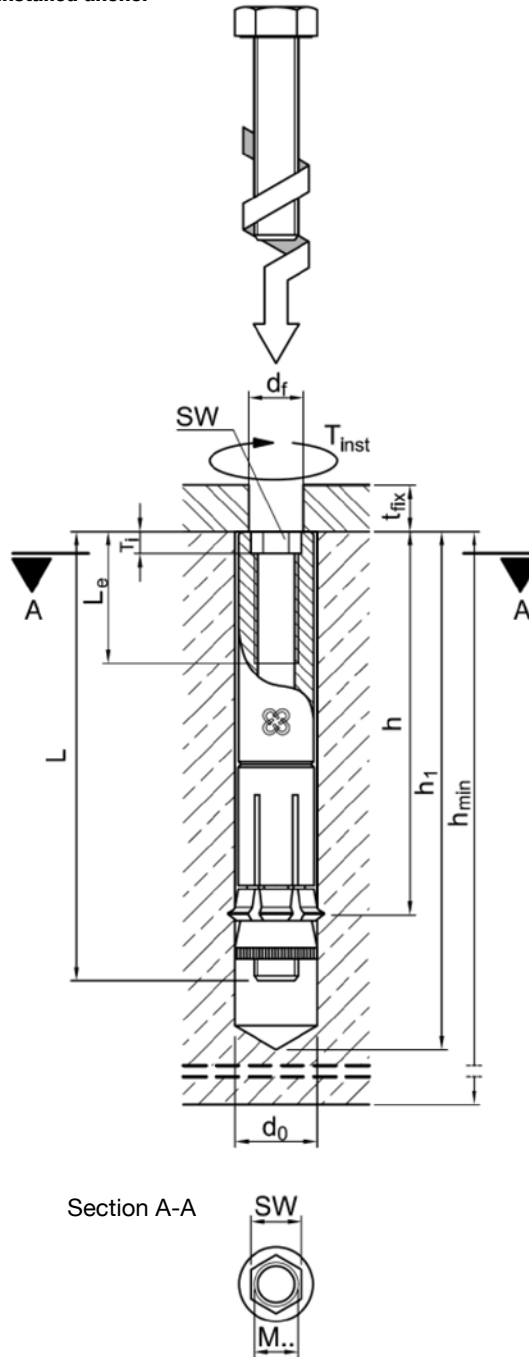

1) The permissible loads have been calculated assuming that grade 8.8 fasteners are used and using the partial safety factors for resistances stated in ETA-01/0011 and a partial safety factor for actions of $\gamma_F = 1.4$. The permissible loads are valid for unreinforced concrete and reinforced concrete with a rebar spacing $s \geq 15$ cm and reinforced concrete with a rebar spacing $s \geq 10$ cm if the rebar is 10 mm or smaller.

2) The permissible shear loads are based on a single anchor without influencing concrete edges. For shear loads applied close to an edge ($c \leq 10 h_e$ or $60 d$) concrete edge failure must be checked per ETAG 001, Annex C, design method A.

3) Concrete is considered non-cracked when the tensile stress within the concrete is $\sigma_t + \sigma_a \leq 0$. In the absence of detailed verification $\sigma_a = 3$ N/mm² can be assumed (σ_t equals the tensile stress within the concrete as a result of external loads, forces on anchors included).

4) If spacings or edge distances become smaller than the characteristic values (i.e. $s \leq s_{cr,N}$ and/or $c \leq c_{cr,N}$) a calculation per ETAG 001, Annex C, design method A must be performed.

For details, see ETA-01/0011.

Custom lengths available on request.

BLS M8-14/40SA A4 Step Iron Anchor, A4 stainless steel

Threaded stud with hex nut and special plastic sleeve

Material: A4-80 stainless steel

Approvals: ETA-05/0013 - Option 1, Expert Report AZ.: 05003



Type	Order Code	Thread Size	Diameter x Depth of drilled hole	Max Fixture Thickness	Fixture Hole Diameter	Eff. Embedment Depth	Total Length	Weight (kg/100pcs)	Box Quantity
BLS M8-14/40SA A4	BLS0814040SA4	M8	14 x 60	20	16	40	85	9.0	25

TECHNICAL DATA

Type	BLS M8-14/40SA A4		
Thread size			M8
Eff. embedment depth	h_{ef}	[mm]	40
Min. edge distance	c_{min}	[mm]	60
Min. member thickness	h_{min}	[mm]	100

Installation data

Drilled hole diameter	d_0	[mm]	14
Drilled hole depth	h_1	[mm]	60
Step iron thickness	t_{fix}	[mm]	20
Step iron hole diameter	d_f	[mm]	16
Wrench size	sw	[mm]	17
Installation torque	T_{inst}	[Nm]	25

Installed anchor

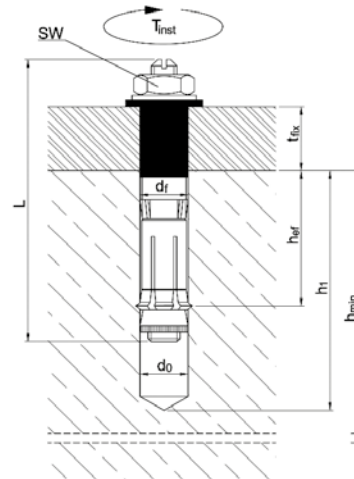

BLS M8-14BS85 Lightning Protection Anchor, Carbon steel, zinc plated

Threaded stud with hex nut and washer

Material: Grade 8.8 Carbon steel, zinc plated



Type	Order Code	Thread Size	Diameter x Depth of drilled hole	Total Length	Weight (kg/100pcs)	Box Quantity
BLS M8-14BS85	BLS0814BS085	M8	14 x 40 to 60	85	7.2	25

BLS M8-14BS85 A4 Lightning Protection Anchor, A4 stainless steel

Threaded stud with hex nut and washer

Material: A4 stainless steel



Type	Order Code	Thread Size	Diameter x Depth of drilled hole	Total Length	Weight (kg/100pcs)	Box Quantity
BLS M8-14BS85 A4	BLS0814BS085A4	M8	14 x 40 to 60	85	7.2	25

Installed anchor

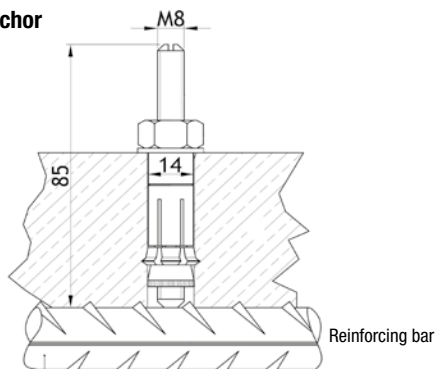



EJOT UK Limited,
Hurricane Close,
Sherburn Enterprise Park,
Sherburn-in-Elmet,
Leeds LS25 6BP.
United Kingdom

Tel: +44 1977 68 70 40

Fax: +44 1977 68 70 41

**Email: liebig@ejot.co.uk
info@ejot.co.uk**



European technical
approval option1