

ULTRAPLUS M12-M36

The undercut anchor for exceptionally high loads in cracked and non-cracked concrete – also for shock and seismic loads.

FUNCTION

When the anchor is installed the expansion segments are driven down to the undercut in the drilled hole. The spring pressure automatically expands the segments into the undercut with an audible “click.” This results in a mechanical undercut connection without any expansion pressure. The “positive undercut” allows perfect bearing of the segments and ensures reliable transmission of the load into the concrete.



European technical approval option1

BENEFITS

- Reliable fixing for high loads in cracked and non-cracked concrete
- High margin of safety due to positive undercutting
- Produced from high strength materials
- The spring automatically compensates for tolerances in the fixture thickness
- Modular design allowing for custom lengths and assemblies
- Reduced edge distances and spacings
- Proven performance history in resisting dynamic loads, shock loads, and seismic loads. Expert reports available for these and other applications.

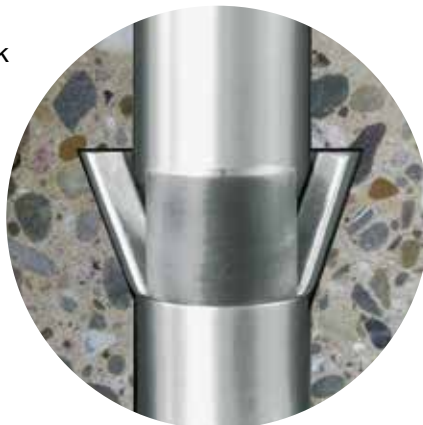

CONSTRUCTION

With hex nut, washer, threaded stud and plastic retaining ring



MATERIAL

High strength carbon steel, stainless steel

BASE MATERIAL

Cracked and non-cracked concrete

APPROVAL

ETA-04/0099 – Option 1 – Approved for cracked and non-cracked concrete

LOAD RANGE

Tension: $N_{perm} = 19.0 - 320.2$ [kN]

Shear: $V_{perm} = 45.2 - 371.4$ [kN]

PRODUCT RANGE

M12 – M36, carbon steel, zinc plated, HDG, sherradized, stainless steel

CHARACTERISTICS

- Positive undercut anchor with strong mechanical interlock
- Instant loading
- Completely removable
- Through-fix installation
- No expansion forces
- Small edge distances and anchor spacings

APPLICATIONS

- Nuclear power plants
- Water treatment plants
- Steel construction
- Industrial plants
- Petrochemical installations
- Cranes

BENEFITS

- Extremely high tensile and shear capacity
- Custom lengths and assemblies readily available
- Positive undercutting (comparable performance to a cast-in headed stud)

PRODUCT DESCRIPTION

The **ULTRAPLUS** undercut anchor is designed for use in applications where reliability and safety are essential, e.g. for anchoring safety relevant components in nuclear power plants, for industrial plants, conveyor systems, cranes, and also for special civil engineering solutions.

The **LIEBIG ULTRAPLUS** was developed to resist very high loads with its unique undercutting technology. After the hole is drilled, a separate undercut is created using the LIEBIG undercutting tool. When the anchor is inserted through the fixture, spring pressure opens the expanding segments.

These lock into the undercut with a clearly audible click. The result is a mechanical interlock without expansion stresses. By applying the specified torque, the fixture is fastened in position. The “positive undercut” allows perfect bearing of the segments and ensures reliable transmission of the load into the concrete.



European technical approval option1



ULTRAPLUS M12-M36

Custom lengths available on request.

ULTRAPLUS Carbon Steel Zinc Plated

Threaded stud with hex nut and washer

*Available in high strength zinc plated, sherradised, HDG and stainless steel

Approval: ETA-04/0099 – Option 1 for cracked and non-cracked concrete



Type	Order Code	Thread Size	Diameter x Depth of drilled hole	Max Fixture Thickness	Fixture Hole Diameter	Eff. Embedment Depth	Total Length	Weight (kg/100pcs)	Box Quantity
UP M12-23/140/20	UP1223140020	M12	23x190	20	24	140	220	48	10
UP M16-30/220/30	UP1630220030	M16	30x300	30	32	220	325	123	5
UP M20-36/250/50	UP2036250050	M20	36x330	50	38	250	380	173	5
UP M24-45/280/60*	UP2445280060	M24	45x410	60	46	280	460	408	2
UP M36-67/420/100*	UP3667420100	M36	67x570	100	68	420	700	1305	1

*Not included in approval. Also available in HDG, sheradized and stainless steel

INSTALLATION ACCESSORIES

Undercutting tool for core drilling rigs with 1/2" drive



Diamond cutting blade



Compatible ULTRAPLUS	Order Code	KG/PC
M12	DH23	2.6
M16	DH30	3.1
M20	DH36	4.1
M24	DH45	5.1
M36	DH67	8.1

Compatible ULTRAPLUS	Order Code	KG/PC
M12	DH23	0.5
M16	DH30	1.0
M20	DH36	1.2
M24	DH45	2.1
M36	DH67	3.3

Both types of undercutting tools are available for either purchase or hire.

Installation data

Thread Size			M12	M16	M20	M24	M36	
Drill hole diameter	d_0	[mm]	23	30	36	45	67	
Drill hole depth	h_1	[mm]	190	300	330	410	570	
Diameter of undercutting	d_1	[mm]	35	47	53.5	74	105	
Undercutting	Δd_{out}	[mm]	6	8.5	8.75	14.5	19	
Clearance hole in the fixture	Through-fix anchorage	d_f	[mm]	24	32	38	46	68
	Installation on threaded stud	d_f	[mm]	14	18	22	26	39
Width across flats	sw	[mm]	24	36	41	50	75	
Installation torque	T_{inst}	[Nm]	120	250	300	790	2000	

ULTRAPLUS

INSTALLATION INSTRUCTIONS

1 Drill hole.



2 Clean hole with a blow pump.



3 Create the undercut using LIEBIG undercutting tool (approximately 15 to 70 seconds depending on the anchor size). Irrigate with water while undercutting.

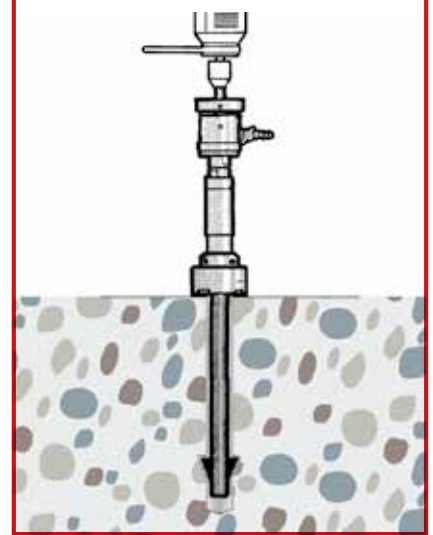

4 Install the LIEBIG ULTRAPLUS undercut anchor. The plastic ring holding the undercutting segments together will remain at the fixture.

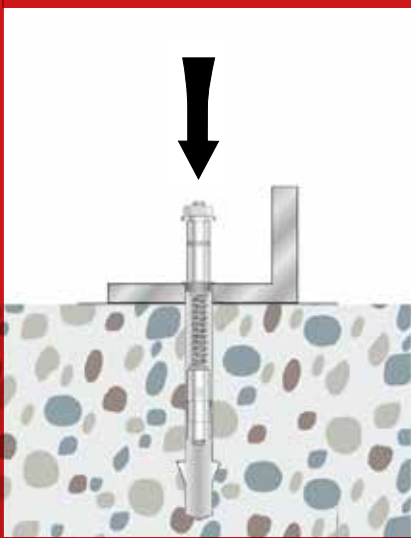

5 Apply the specified installation torque using a calibrated torque wrench – the ULTRAPLUS undercut anchor is now installed and can resist loads immediately!

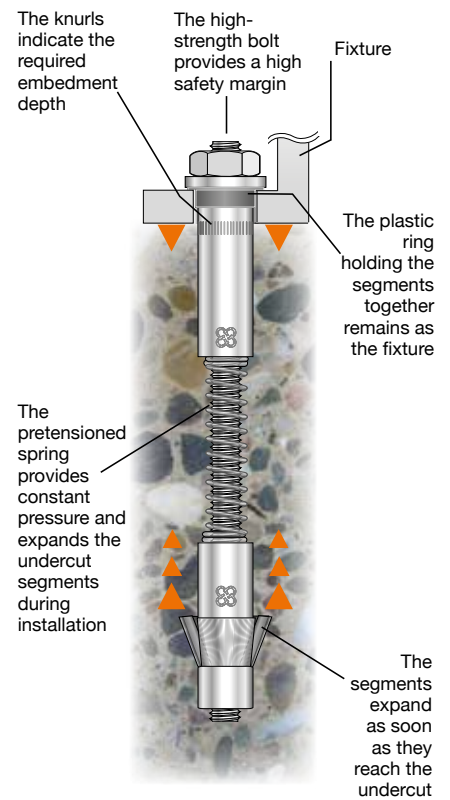
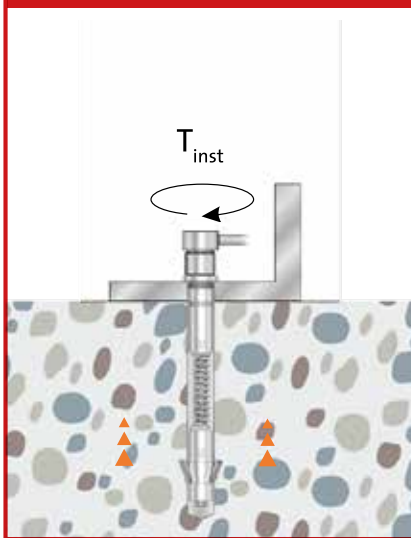

Custom lengths available on request.

ULTRAPLUS Carbon Steel Zinc Plated

Permissible loads for single anchors with no influencing edge distances or spacings. Loads are calculated using partial safety factors from ETAG 001 and the characteristic anchor and installation data from this catalogue. Design calculations shall follow the requirements of ETA-04/0099. Material: Carbon steel zinc plated. Please contact EJOT UK for load and performance data for the stainless steel version, or consult the technical manual.

Thread Size	M12	M16	M20	M24	M36
Effective embedment depth (mm)	140	220	250	280	420
Type UP	M12-23/140/...	M16-30/220/...	M20-36/250/...	M24-45/280/...	M36-67/420/...

Permissible tension loads¹⁾

N_{perm}	Concrete	Crack Class	[kN]	M12	M16	M20	M24	M36
	Cracked	C20/25	[kN]	19.0	35.7	45.2	80.3	147.6
		C30/37	[kN]	23.2	43.6	55.2	98.0	180.0
		C40/50	[kN]	26.9	50.4	63.8	113.3	208.1
		C50/60	[kN]	29.5	55.4	70.1	124.5	228.7
	Non-Cracked Concrete ³⁾	C20/25	[kN]	28.6	45.2	66.7	111.9	206.6
		C30/37	[kN]	34.9	55.2	81.3	136.5	252.0
		C40/50	[kN]	40.3	63.8	94.0	157.8	291.3
		C50/60	[kN]	43.4	70.1	103.3	173.5	320.2

Permissible shear loads^{1) 2)}

V_{perm}	Concrete	Crack Class	[kN]	M12	M16	M20	M24	M36
	Cracked	C20/25	[kN]	19.0	35.7	45.2	80.3	147.6
		C30/37	[kN]	23.2	43.6	55.2	98.0	180.0
		C40/50	[kN]	26.9	50.4	63.8	113.3	208.1
		C50/60	[kN]	29.5	55.4	70.1	124.5	228.7
	Non-Cracked Concrete ³⁾	C20/25	[kN]	28.6	45.2	66.7	111.9	206.6
		C30/37	[kN]	34.9	55.2	81.3	136.5	252.0
		C40/50	[kN]	40.3	63.8	94.0	157.8	291.3
		C50/60	[kN]	43.4	70.1	103.3	173.5	320.2

Installed anchor

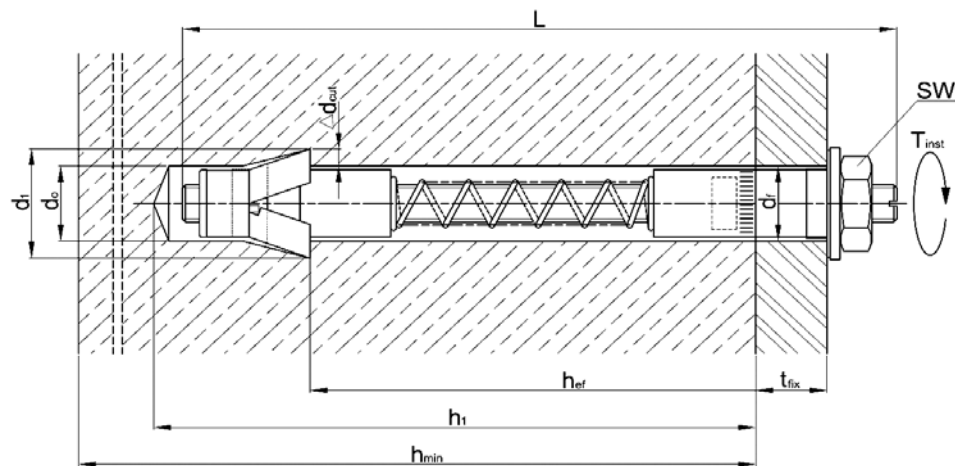

1) The permissible loads have been calculated using the partial safety factors for resistances stated in the ETA-approval and a partial safety factor for actions of $\gamma_F = 1.4$. The permissible loads are valid for unreinforced concrete and reinforced concrete with a rebar spacing $s \geq 15$ cm and reinforced concrete with a rebar spacing $s \geq 10$ cm if the rebar is 10 mm or smaller.

2) The permissible shear loads are based on a single anchor without influencing concrete edges. For shear loads applied close to an edge ($c \leq 10 h_{ef}$ or $60 d$) concrete edge failure must be checked per ETAG 001, Annex C, design method A.

3) Concrete is considered non-cracked when the tensile stress within the concrete is $\sigma_L + \sigma_R \leq 0$. In the absence of detailed verification $\sigma_R = 3$ N/mm² can be assumed (σ_L equals the tensile stress within the concrete as a result of external loads, forces on anchors included).

4) If spacings or edge distances become smaller than the characteristic values (i.e. $s \leq s_{crit}$ and/or $c \leq c_{crit}$) a calculation per ETAG 001, Annex C, design method A must be performed. For details, see ETA-04/0099.

5) The permissible bending moments are only valid for the threaded stud (e.g. in case of a distance mounting).

6) This h_{min} only applies when the remote face of the concrete is inspected to ensure there has been no break-through as a result of drilling. Otherwise $h_{min} = 360$ mm (M16) and $h_{min} = 400$ mm (M20).



EJOT UK Limited,
Hurricane Close,
Sherburn Enterprise Park,
Sherburn-in-Elmet,
Leeds LS25 6BP.
United Kingdom

Tel: +44 1977 68 70 40

Fax: +44 1977 68 70 41

**Email: liebig@ejot.co.uk
info@ejot.co.uk**



European technical
approval option1



The ORIGINAL Anchoring Technology Now with EJOT® Global Support