

EJOT® Joining technology in multi material designs for lightweight applications

Flexible fastening solutions for dissimilar materials

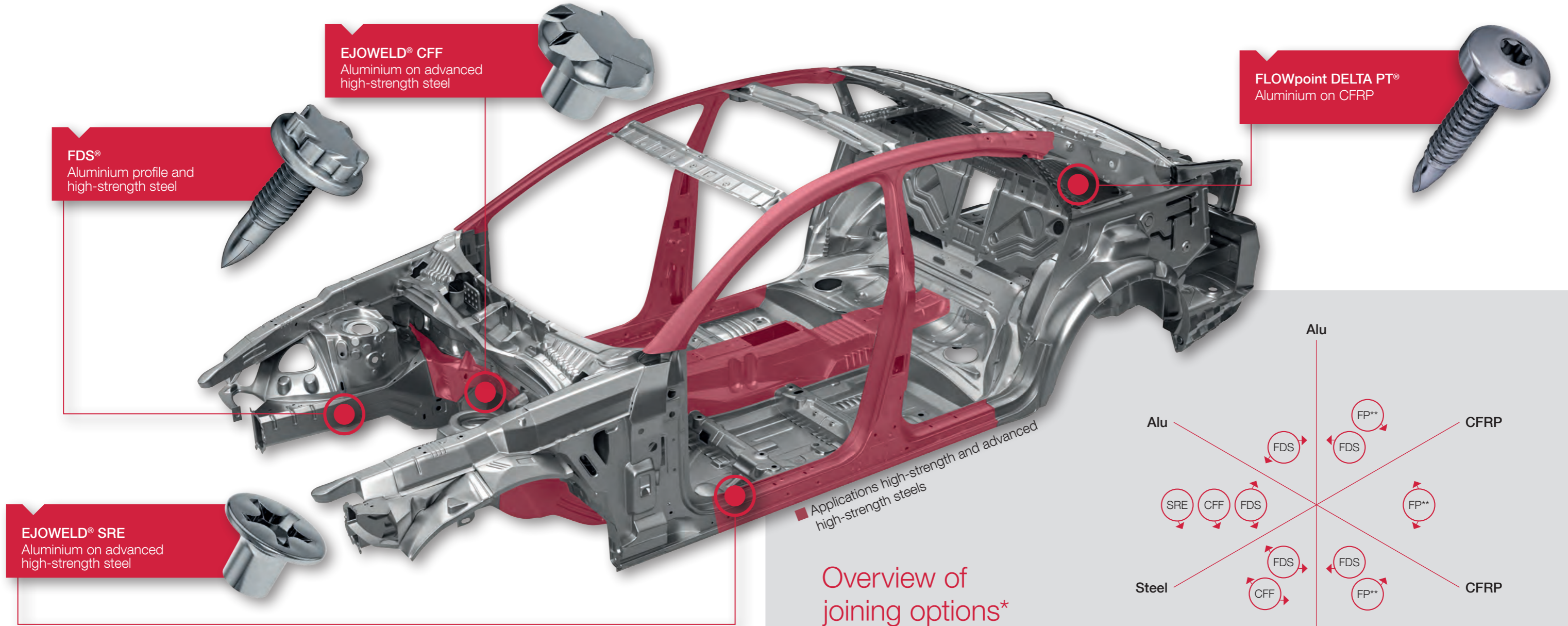

Applications high-strength and advanced high-strength steels

Overview of joining options*

*Please note material strengths and pre-peroration
 **FLOWpoint DELTA PT®
 → Joining direction

	Clamping part						
	Aluminium sheet	Aluminium casting	Steel (to 600 MPa)	High-strength steel (600 - 800 MPa)	Advanced high-strength steel (800 - 1000 MPa)	Ultra-high strength steel (1000 - 1600 MPa)	FRP
Aluminium profile	●	●	●	● ¹	● ¹	● ¹	● ¹
Aluminium sheet	●* ●	●* ●	●	● ¹	● ¹	● ¹	●* ● ¹
Aluminium casting	●* ●	●* ●	●	● ¹	● ¹	● ¹	●* ● ¹
Steel (to 600 MPa)	● ●	● ●	● ¹ ●	● ¹ ● ¹	● ¹ ● ¹	● ¹ ● ¹	● ¹
High-strength steel (600 - 800 MPa)	● ● ¹	● ● ¹	● ¹ ● ¹	● ¹ ● ¹	● ¹ ● ¹	● ¹ ● ¹	● ¹
Advanced high-strength steel (800 - 1000 MPa)	● ● ¹	● ● ¹	● ¹ ● ¹	● ¹ ● ¹	● ¹ ● ¹	● ¹ ● ¹	● ¹
Ultra-high strength steel (1000 - 1600 MPa)	●	●	● ¹	● ¹	● ¹	● ¹	
Steel (> 1600 MPa)	●	●	● ¹	● ¹	● ¹	● ¹	
FRP and hybrid composites							

- = EJOWELD® without pre hole
- ¹ = EJOWELD® with pre hole
- * = On request
- = FDS® without pre hole
- ¹ = FDS® with pre hole

Threaded/ base material	Clamping part			
	Aluminium sheet (t < 2 mm)	CFRP thermoplastic	CFRP duroplastic	Other FRP
CFRP thermoplastic	▲ ▲ ¹	▲ ▲ ¹	▲ ¹	Suitable for fastening; Screw tests required in individual cases
CFRP duroplastic	▲ ¹	▲ ▲ ¹	▲ ¹	
Other FRP	Suitable for fastening; Screw tests required in individual cases			

The joining parameters must be determined with application engineering testing.

- ▲ = FLOWpoint DELTA PT® without pre hole
- ▲¹ = FLOWpoint DELTA PT® with pre hole

FDS®

Joints with one-sided accessibility in vehicle body construction



The EJOT FDS® screw enables a high strength screw joint, due to increased thread engagement in the formed through draught, in both steel plate and aluminium applications.

The one-sided accessibility of the part provides for an assembly into hollow profiles (hydroformed or aluminium extrusion profiles) without any counter support, as might be necessary for other joining methods. Modern space frame structures place high demands on the joining technology of the body shell because of the composite construction and often one-sided access. The material order when fastening without pre hole should be "thin on thick" or "soft on hard" respectively, as higher tightening torques can be reached and gaps between the two components can be minimised.

Assembly stages:

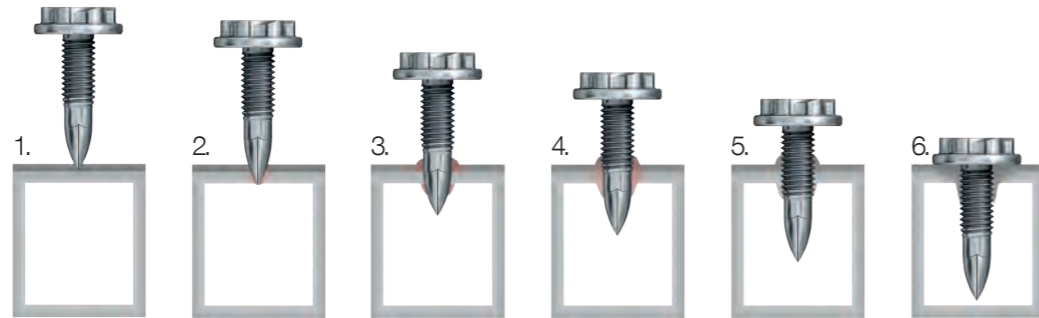

1. Warming up
2. Penetration of the material
3. Forming of the draught
4. Thread forming
5. Full thread engagement
6. Tightening

-  1.5 - 3.0 s
-  3.0 - 5.0 g
-  One-sided

Product animation:



Advantages:

- One-sided joining direction
- Removable and high quality screw joint, without part preparations such as pre-drilling or punching
- No tolerance problems with clearance and threaded holes
- No material waste while forming the draught / no chips during thread forming
- Easy removal and recycling

Contact: EJOT Hotline, phone +49 2751 529-123, fax 529-98 123, e-mail hotline@ejot.com

EJOWELD®

Efficient, flexible and proven friction element welding for joints in multi material and lightweight construction



EJOWELD® CFF



EJOWELD® SRE



EJOWELD® is a thermomechanical process, during which energy is generated through rotatory friction between the element and the base plate.

This leads to plastic deformation of the joining element and welding with the base plate. The cover plate is simply penetrated and fixed between element head and base plate. The connection results from a combination of form-fit, force closure and adhesive bond.

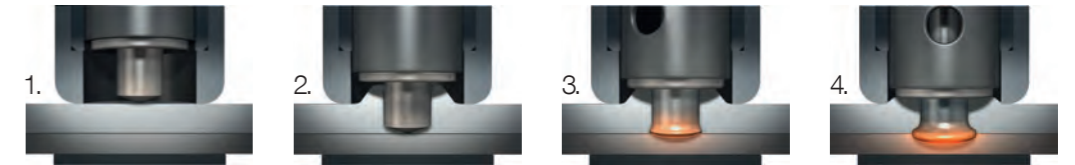
Assembly stages:



1. Penetration of the cover sheet (Lightweight material)
2. Cleaning and activation of the surfaces
3. Plastification of friction element and base plate
4. Compression / forming of the welded joint

-  0.7 - 2.0 s
-  0.7 - 1.7 g
-  Two-sided

Product animation

EJOWELD® CFF:



Product animation

EJOWELD® SRE:



Advantages:

- No pre hole
- No pre and post treatment of the joining partners
- No intermetallic phases
- Fully automatable
- Corrosion resistant
- Low energy balance compared to welding

Contact: Toni Müller, phone +49 36252 42-415, e-mail tmueller@ejot.com
Please visit our new website www.ejoweld.com

EJOWELD® equipment

Modular setting technology for flexible applications



C2



C3.5



C6



Anvil 20, 50, 80, 110, 140, 170 mm

With the development of proprietary equipment, EJOT consistently implements the concept of providing its customers with everything from a single source, from joining elements to installation technology through to service.

In addition to a range of setting tools, carrier systems and feeders, the controller constitutes the central component of EJOWELD® equipment. It provides all system components with energy, controls the welding process and monitors the joining quality. With various robot interfaces and data protocols for quality or data backup, EJOWELD® equipment is prepared, way beyond today's normal sector requirements, for upcoming standards such as "Industry 4.0".

EJOWELD® equipment:



Setting tool with C2 frame and optional 2nd feeder

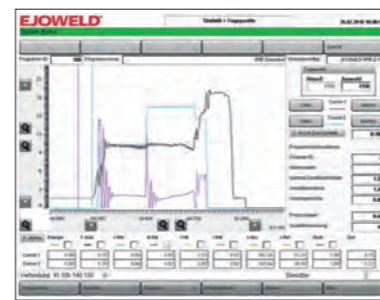

Control unit display

Advantages:

- Modular design
- Minimal interfering contour
- Low-noise and emission-free joining
- Diverse communication options
- Fully automatic and robot-compatible
- Energy-saving drive technology and optional energy recovery

Contact: Toni Müller, phone +49 36252 42-415, e-mail tmueller@ejot.com
Please visit our new website www.ejoweld.com

FLOWpoint DELTA PT®

Joining technology for components of thermoplastic CFRP in multi material and lightweight design without pre hole



The FLOWpoint DELTA PT® screw is an innovative fastener developed to meet the challenging demands of joining these highly engineered carbon fibre reinforced plastic (CFRP) materials.

The FLOWpoint DELTA PT® is a self-piercing and selftapping screw that penetrates both the clamping part and mating material without a pre hole. The optimised DELTA PT® thread geometry forms a strong female thread in the CFRP.

Assembly stages:

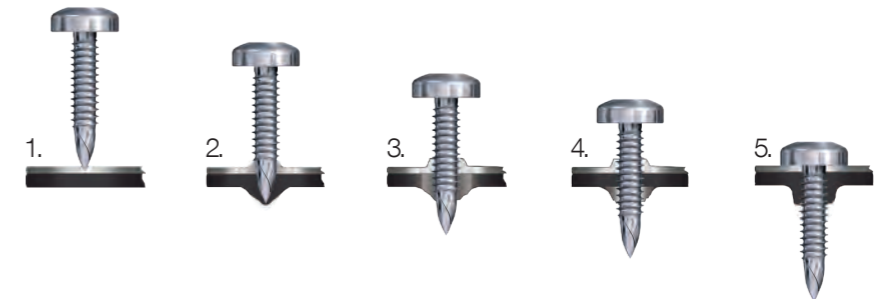

1. Rotation of screw and application of axial end load
2. Warming up and penetration of the material
3. Screw hole calibration and forming of the extrusion
4. Thread forming and full thread engagement
5. Tightening

- 2.0 - 3.8 s
- 1.2 - 3.8 g
- One-sided

Product animation:



Advantages:

- No pre hole required, no positioning tolerance needed
- Removable and high quality one side access screw joint, without part preparation such as pre-drilling or punching
- Applicable for many varieties of fibre-reinforced plastics
- Easy removal and recycling
- Available in stainless steel A2 / A4, steel, aluminium and titanium
- Hybrid joining possible (e.g. aluminium sheet metal on CFRP materials)

Contact: EJOT Hotline, phone +49 2751 529-123, fax 529-98 123, e-mail hotline@ejot.com

Calculation service



The calculation service allows design and fastener engineers to check the joining parameters in advance. The use of the prognosis programs for the preliminary design of multi-material connections saves time and reduces costs.

Automotive Center Südwestfalen GmbH



Automotive Center Südwestfalen GmbH (acs) was founded in 2011 and is a platform for research and development tasks, as well as knowledge transfer between car manufacturers, suppliers and universities in South Westphalia.

The company provides a modern infrastructure, equipment, software and experts for projects and tasks in the field of research and development. Its expertise covers the field of car body and chassis, as well as rational manufacturing processes for metal, plastics and hybrid material combinations.

Component suppliers and car manufacturers can implement projects here to address the issues of functional and cost-efficient lightweight design and meet the special requirements of electromobility. For this purpose, the Automotive Center Südwestfalen GmbH offers the space, resources, human resources and an innovative development environment.

EJOT as a shareholder also benefits from this expertise and regularly assigns acs to conduct research and development tasks.

www.acs-innovations.de

EJOT®

EJOT SE & Co. KG
Market Unit Industry
Im Herrengarten 1
57319 Bad Berleburg, Germany

Phone: +49 2751 529-0
Fax: +49 2751 529-559
E-mail: industrie@ejot.com
Internet: www.ejot.com/industry

Legal notice

Published by:
EJOT SE & Co. KG
Market Unit Industry
D-57319 Bad Berleburg

© by EJOT SE & Co. KG
EJOT®, DELTA PT®, DELTA CALC®, EJOWELD®
and FDS® are registered trademarks of
EJOT SE & Co. KG.

Subject to technical changes.