



EJOBAR PVC

Fixing solar systems
to reinforced PVC
membrane roofs

Technical guidelines for installation



Bringing it together

A proven fixing solution for solar systems to PVC membrane protected roofs

Since its introduction to the EJOT product portfolio, EJObar has become a recognised and trusted fixing solution for mounting solar array systems onto flat roofs that are waterproofed using reinforced PVC single-ply membrane.

EJObar's performance objective is to act as a secure fixing interface between the solar framing system and the roofing membrane, whilst supporting the integrity of the PVC single-ply membrane installation.



HTK 2G 50 Tubewasher / TKR carbon steel or TKE A4 grade stainless steel fastener for steel and timber substrate.



Characteristic resistance data can be referenced in European Technical Assessment: ETA 07/0013



EcoTek 50 Tubewasher / FBS-R carbon steel fastener for concrete or FPS-E A2 grade stainless steel fastener for aerated concrete substrate.



Characteristic resistance data can be referenced in European Technical Assessment: ETA 07/0013



JF3 EJOFAST Fastener
Range: Easy attachment solar frame to EJObar.



Characteristic withdrawal data can be referenced in European Technical Assessment: ETA-22/0126

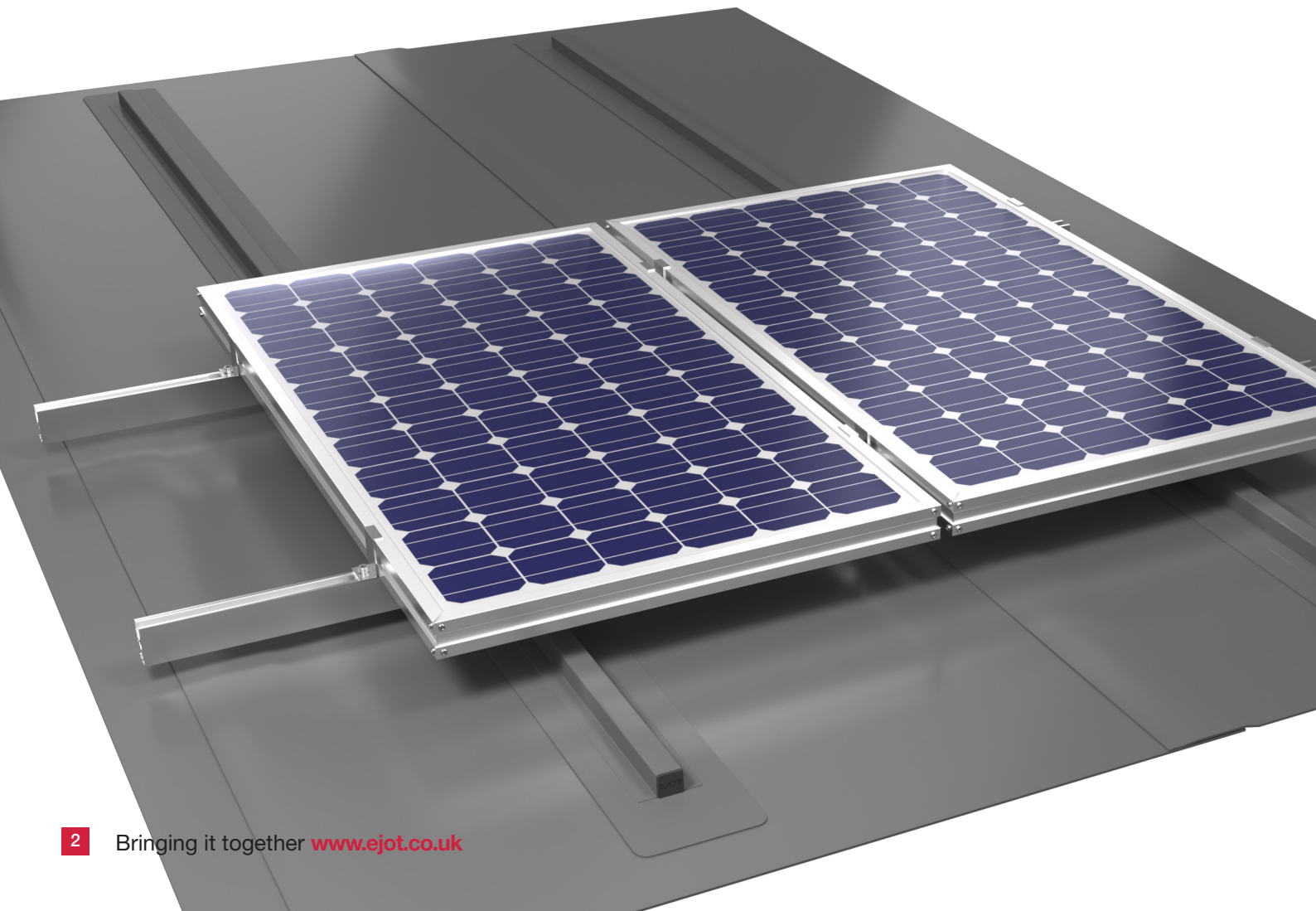

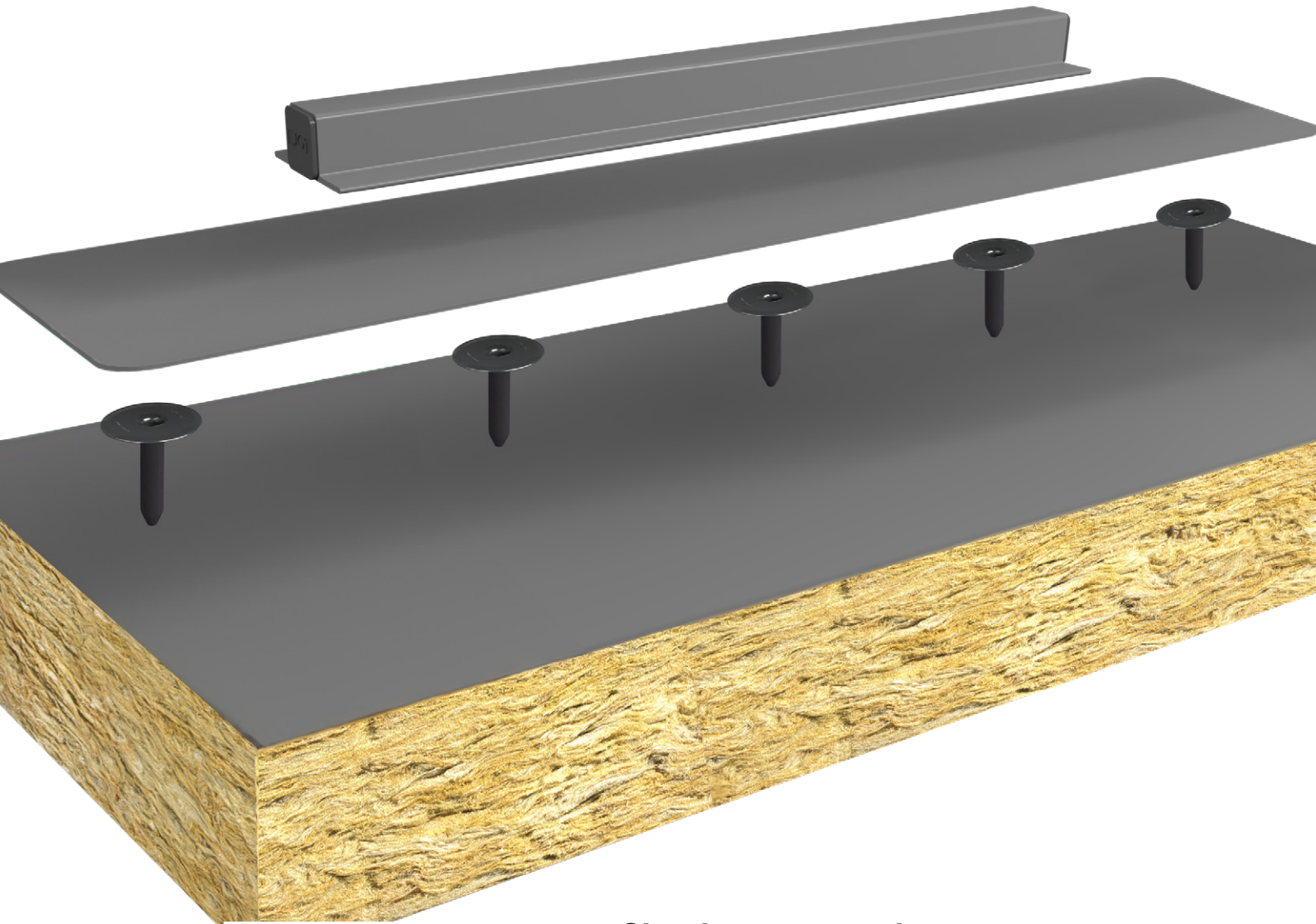

For mechanical design detail, engineers should reference page 11 onwards

Simple to use and easy to install

EJOBAR can easily be installed to new or existing reinforced PVC single ply membrane roofs, where approved by the specific membrane manufacturer.

The area of the roof that will receive the EJOBAR must be fully prepared and cleaned using an appropriate solvent cleaner specific to the PVC membrane being installed onto.

A predetermined number of tubewashers are installed beneath a 150mm wide PVC membrane cover strap that is approved for use by the manufacturer of existing PVC rooftop covering. The full perimeter of EJOBAR is hot air welded onto the roofing membrane by a suitably qualified and experienced installer, using a seam roller to ensure good adhesion to the membrane.

Strength and performance

Test procedures for EJOT EJOBAR have been conducted at the EJOT UK Applitec laboratory and processed in line with European Norm procedure: EN-12316-2.

Tests have taken into consideration a variety of reinforced PVC membranes. For specific membrane data, please contact the EJOT UK Technical Team to access mechanical resistances.

It should also be noted that in the context of weight loading, the performance of EJOBAR is directly influenced by the construction of the roof and the compressive performance of the insulation type. Additionally the position of the EJOBAR in relationship to the valley or crowns of any steel or aluminium decking should be considered.

Further key notes:

- EJOT EJOBAR must only be considered for use with a minimum thickness of 1.5mm reinforced PVC.
- The thickness of EJOBAR's extruded aluminium bar is 2.0mm, produced from high strength Al 6063 T6 with minimum yield strength of 170N/mm², per EN 755-2.
- Characteristic withdrawal data for EJOT fastener JF3-2 5.5 x L and JT3-2 6.0 x L can be referenced in European Technical Assessment: ETA-22/0126 and DIBT approval Z-72.1-1 respectively.
- EJOT EJOBAR is used in conjunction with the correct tubewasher / fastener combination such as HTK / TKR or EcoTek / FBS-R, more combinations and mechanical resistances are available and are detailed in European Technical Assessment: ETA 07/0013.

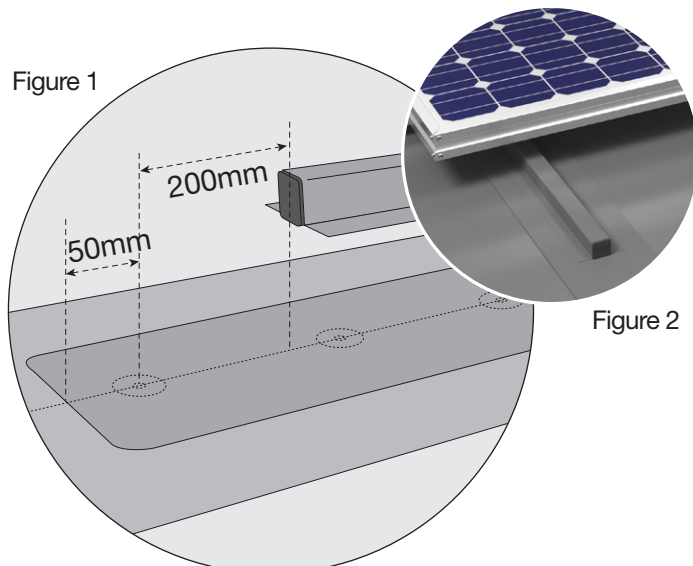
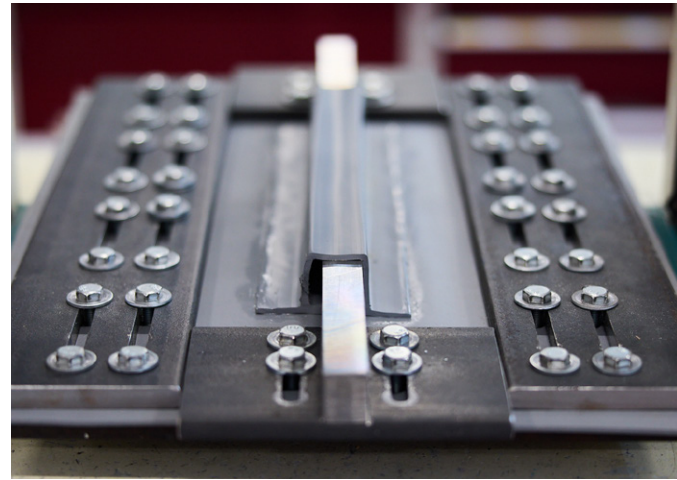

NOTE:

Additional fasteners must be installed beyond the length of the EJOBAR continuing the centre spacing at $200\text{mm} \leq S \leq 500\text{mm}$. The spacings are determined by a wind load calculation.

The cover strap should adequately cover the continued line of fasteners and extend a minimum of 100mm past the final fastener at each end for each EJOBAR installation. The cover strap should be a minimum width of 150mm (figure 1).

EJOBAR must extend a minimum of 250mm past the railing system.

For further dimensioning conditions, see Page 12.

Installation: Steel deck substrate

Cover strap to reinforced PVC membrane

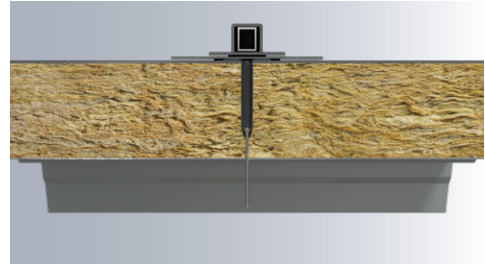

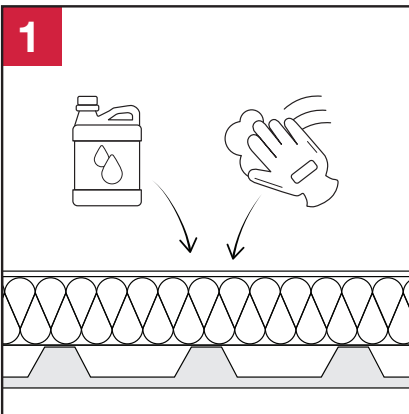

1 Prepare membrane with appropriate cleaning agent.

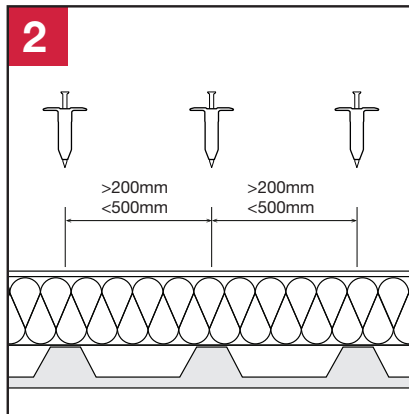

2 Install HTK + TKR combination, spaced between 200-500mm.

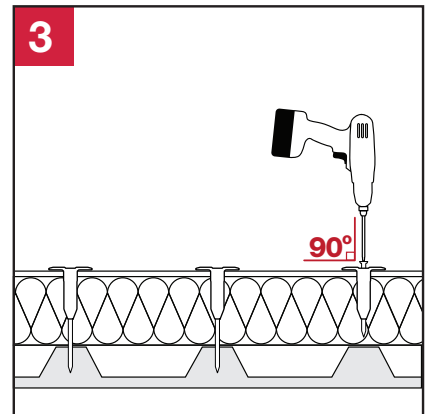

3 Ensure fasteners are secured at 90°.

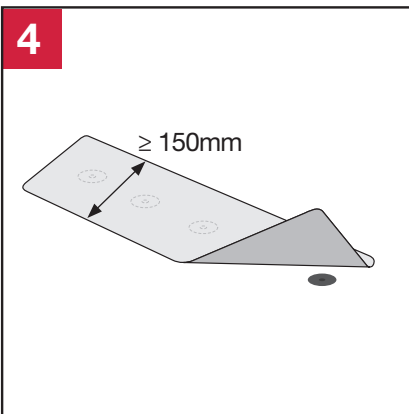

4 Apply ≥ 150.0mm wide cover strap over the HTK + TKR Combination.

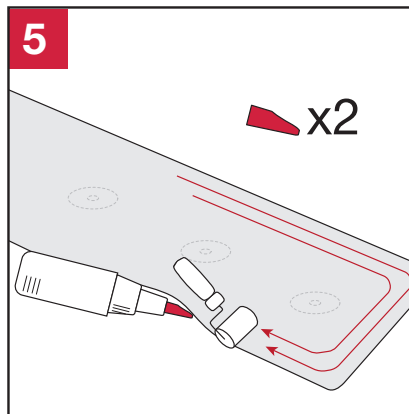

5 Hot air weld the cover strap using hot air weld gun and silicone roller.

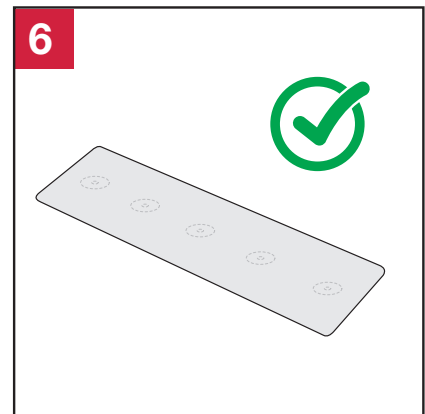





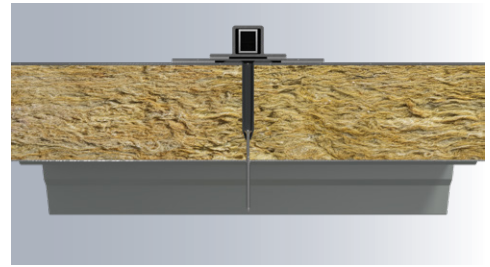

6 Cover strap installation complete, ready to begin EJOBAR installation.

Installation: Steel deck substrate

EJObar to Cover Strap

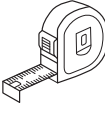
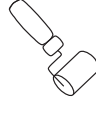

 Marker	 PPE
 Cleaning Agent	 Cleaning Cloth
 Measure	 Seam Roller
	 Hot Air Weld Tool

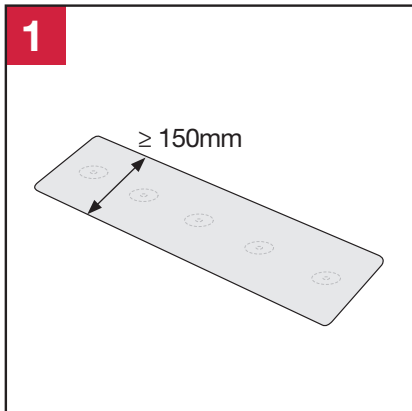

1 Ensure cover strap has been correctly fitted and ready.

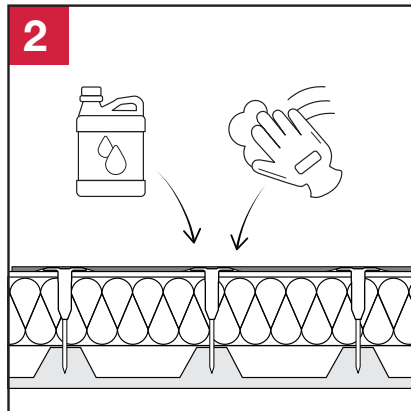

2 Prepare cover strap with appropriate cleaning agent.

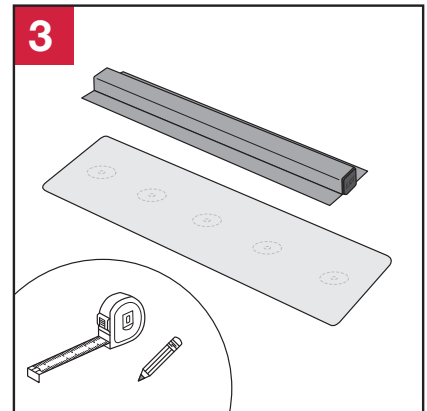

3 Measure and mark positioning for the EJObar.

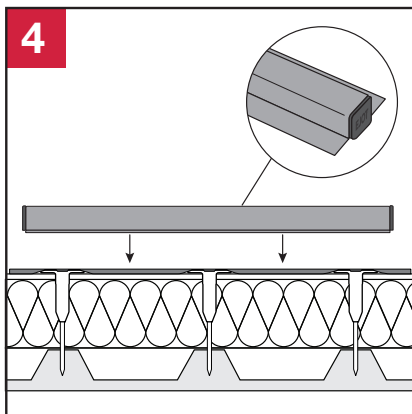

4 Place EJObar over cover strap.

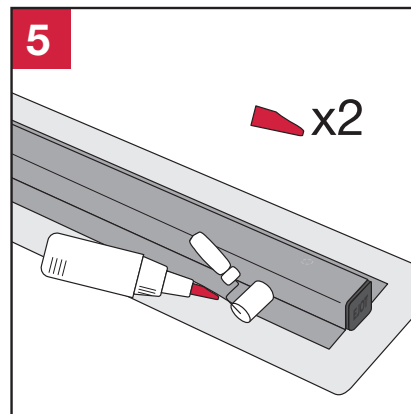

5 Hot air weld the cover strap using hot air weld gun and silicone roller.

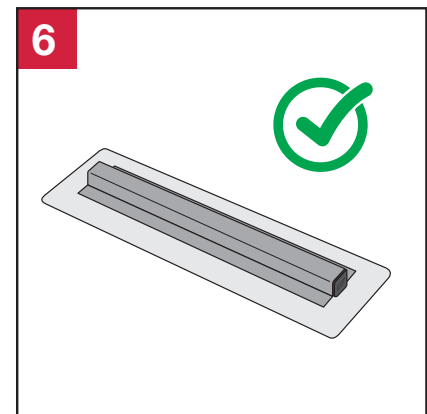

6 Installation complete, ready for frame fixing.

Installation: Timber deck substrate

Cover strap to reinforced PVC membrane

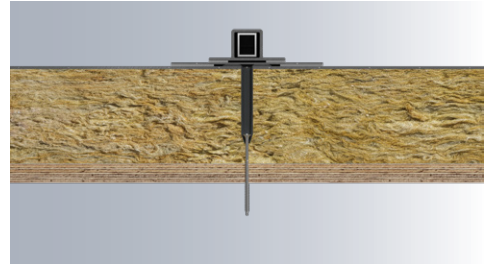

	PPE		Screwgun
	Marker		Cleaning Agent
	Measure		Seam Roller
	Cleaning Cloth		Hot Air Weld Tool

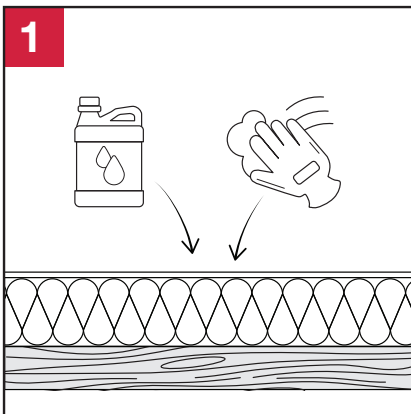

1 Prepare membrane with appropriate cleaning agent.

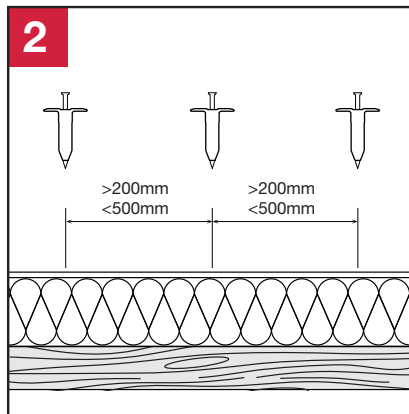

2 Install HTK + TKR combination, spaced between 200-500mm.

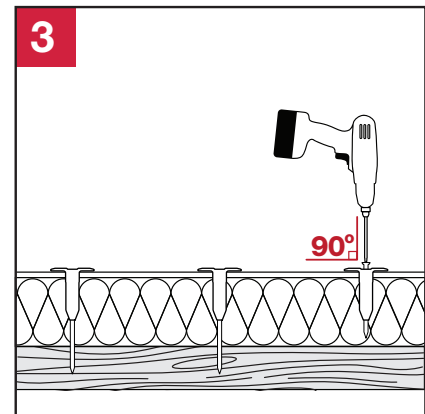

3 Ensure fasteners are secured at 90°.

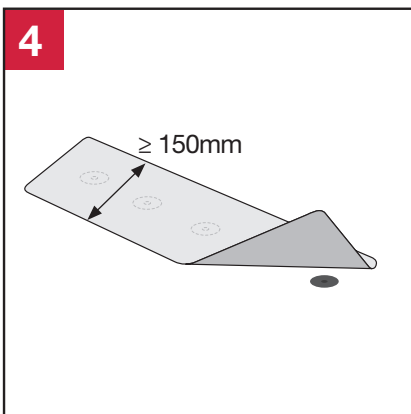

4 Apply ≥ 150.0mm wide cover strap over the HTK + TKR Combination.

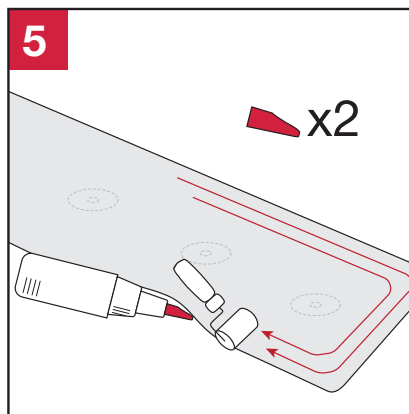

5 Hot air weld the cover strap using hot air weld gun and silicone roller.

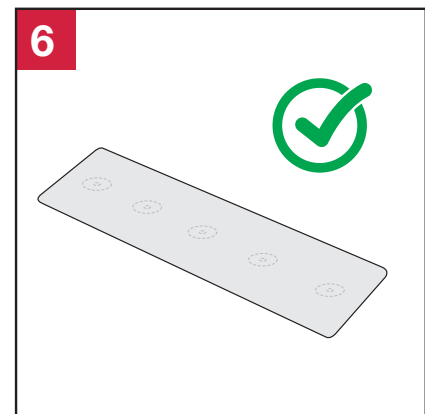



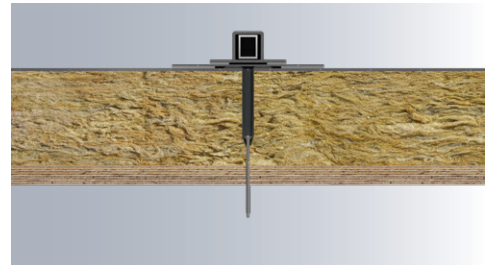

6 Cover strap installation complete, ready to begin EJOBAR installation.

Installation: Timber deck substrate

EJObar to Cover Strap

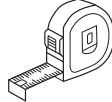
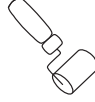
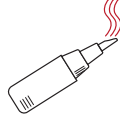

 Marker	 PPE
 Cleaning Agent	 Cleaning Cloth
 Measure	 Seam Roller
	 Hot Air Weld Tool

1

≥ 150mm

Ensure cover strap has been correctly fitted and ready.

2

Prepare cover strap with appropriate cleaning agent.

3

Measure and mark positioning for the EJObar.

4

Place EJObar over cover strap.

5

x2

Hot air weld the cover strap using hot air weld gun and silicone roller.

6

Installation complete, ready for frame fixing.

Installation: Concrete deck substrate

Cover strap to reinforced PVC membrane

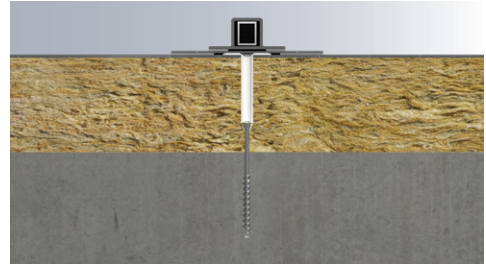
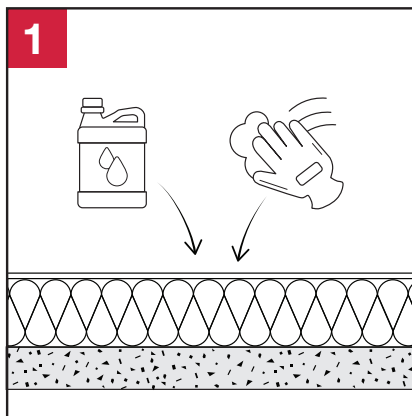
1 Prepare membrane with appropriate cleaning agent.

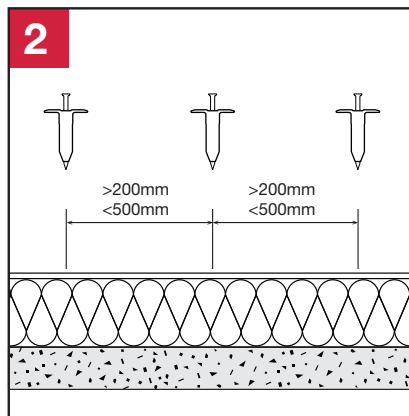

2 Install FBS-R + EcoTek combination, spaced between 200-500mm.

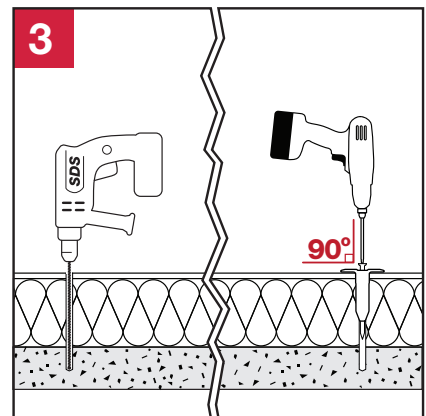

3 Ensure fasteners are secured at 90°.

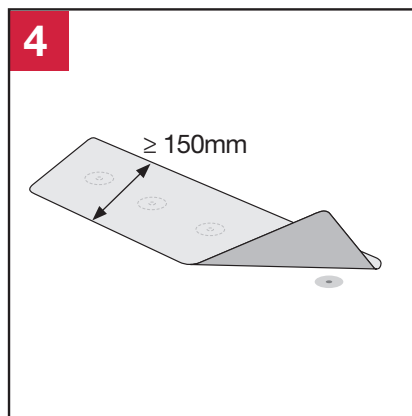

4 Apply ≥ 150.0mm wide cover strap over the FBS-R + EcoTek Combination.

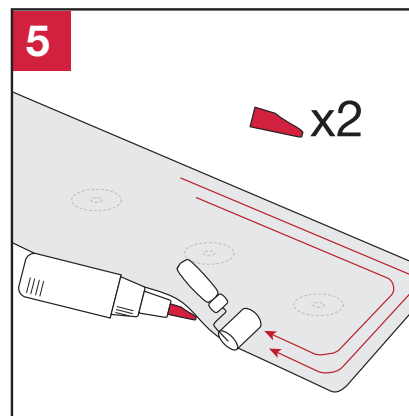

5 Hot air weld the cover strap using hot air weld gun and silicone roller.

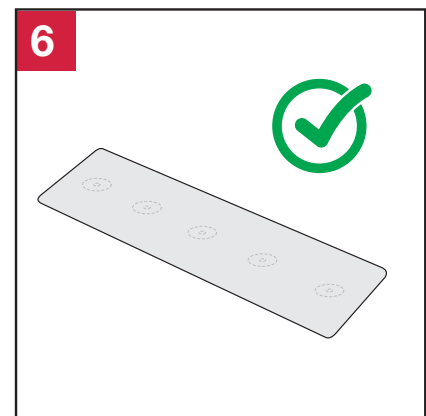

6 Cover strap installation complete, ready to begin EJOBAR installation.

Installation: Concrete deck substrate

EJObar to Cover Strap

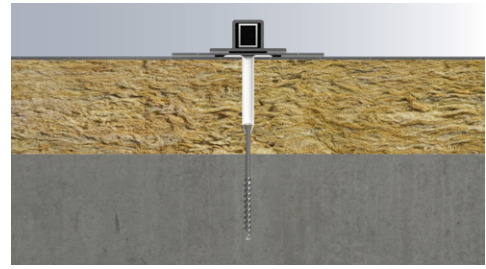
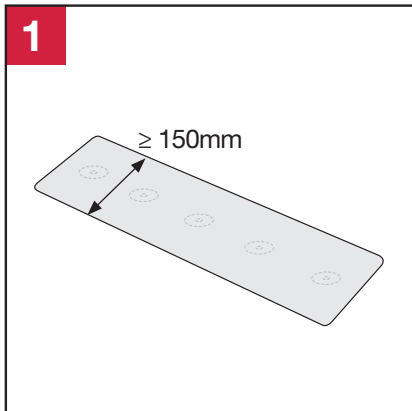
1 Ensure cover strap has been correctly fitted and ready.

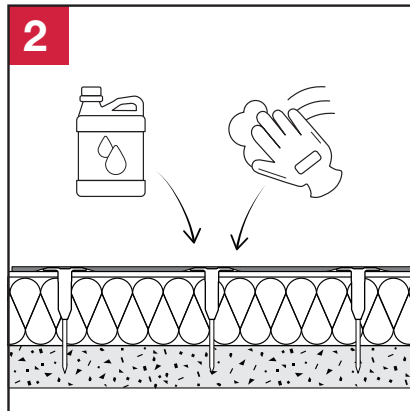

2 Prepare cover strap with appropriate cleaning agent.

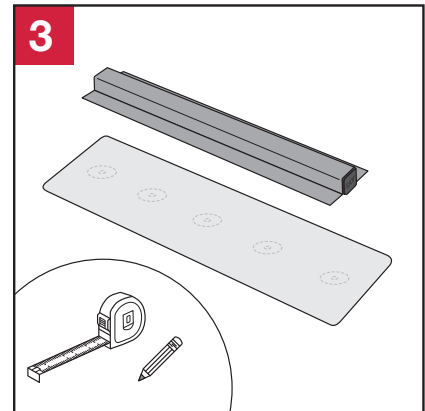

3 Measure and mark positioning for the EJObar.

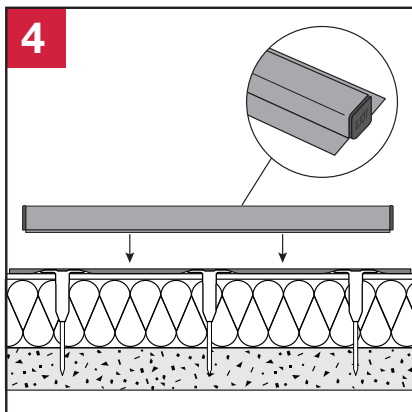

4 Place EJObar over cover strap.

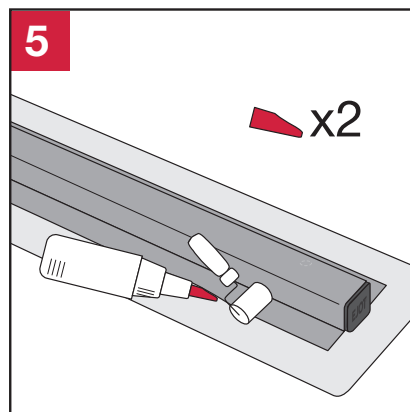

5 Hot air weld the cover strap using hot air weld gun and silicone roller.

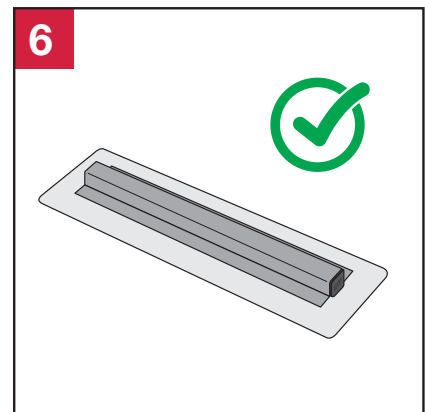

6 Installation complete, ready for frame fixing.

General Requirements for Design & Installation

Installation Conditions

- EJObar can only be attached to reinforced PVC membranes with a minimum thickness of 1.5mm.
- EJObar can be used on both mechanically fastened and adhered systems.
- Additional fasteners must be fixed directly beneath where the EJObar is positioned.
- A cover strap with minimum width of 150mm must be hot air welded to membrane, covering the additional fasteners, retaining a hermetic seal.
- The cover strap must be compatible with the existing membrane. Confirmation must be sought from membrane OEM to ensure no warranties are violated.
- Cover strap must be minimum 1.5mm thickness reinforced PVC.
- A minimum pitch of 3° is recommended to avoid excessive soiling of solar modules installed parallel to the roof. If the pitch is greater than 30° please contact EJOT Technical.
- Direct fastening of PV modules to EJObar is not allowed. A railing system or similar is required to spread load evenly. [See illustration below.](#)
- On existing roofs where the substructure is undetermined an onsite pullout test is required.
- The compression strength of insulation must be verified by a suitably qualified expert, to ensure it is capable of withstanding additional loading produced by PV system.
- The design only applies to vertical loads. In situations where transverse loads are identified as critical, independent resistance verification must be made.
- Loads/actions acting on roofing system, including solar attachments, should be independently verified in accordance with EN 1991-1-4 (Eurocode 1. Actions on structures - General actions - Wind actions).
- If the design falls outside of this document's criteria, please contact EJOT UK for consultation.
- Verification must be undertaken by a responsible structural engineer.

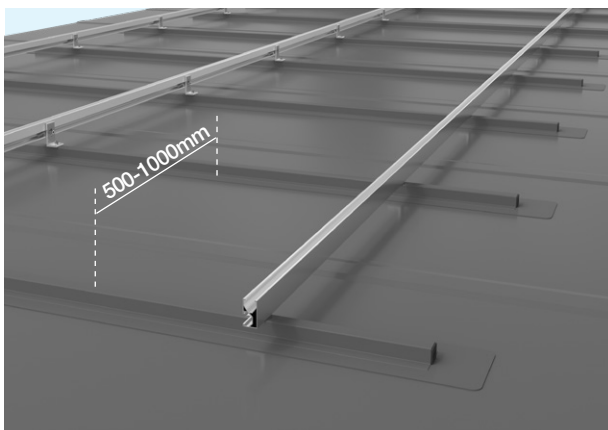

The spacing between parallel bars in a connected system should be a minimum of 500mm and maximum of 1000mm. See Dimensioning Conditions on Page 12.

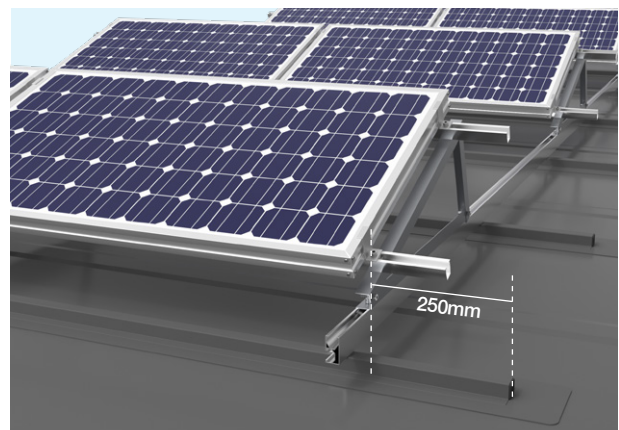

The EJObar must extend 250mm past the edge of the aluminium railing system. See Dimensioning Conditions on Page 12.

Dimensioning Conditions

- An additional fastener must extend the row by a further 200mm from each end of the EJOBAR - **see figure 1.**
- The cover strap must extend the row by a further (min.) 50mm from each end of the EJOBAR. - **see figure 2.**
- Rail attachment must extend minimum 100mm past EJOBAR profile as shown in **figure 3.**
- 0.5m is the minimum allowable length, where extended onto a multiple PV arrangement row - **see figure 4.**
- The spacing between parallel bars in a connected system should be a minimum of 500mm and maximum of 1000mm.
- No PV panels allowed within 500mm of roof border.
- In multiple PV arrangements, the minimum allowable EJOBAR is 3m.
- When installing parallel to the roof slope, the maximum allowed length is 12m (4x3m) without an expansion joint. When more than 12m concurrent length is deployed a joint of 50 mm is required (expansion joint required for the aluminium).
- When used in stand alone, singular arrangement, 1m lengths are permitted.
- If EJOBARS are installed perpendicular to water flow, the minimum gap between bars is 150mm - **see figure 5.**
- The EJOBAR must extend 250mm past the edge of rail system - **see figure 6.**
- In perimeter and corner areas, spacing must be at least 500mm between bars.

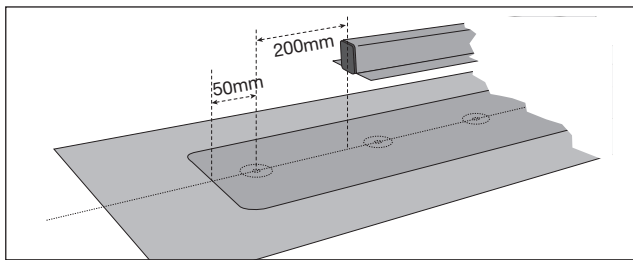

Figure 1

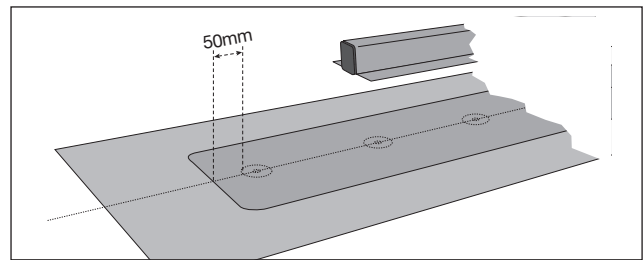

Figure 2

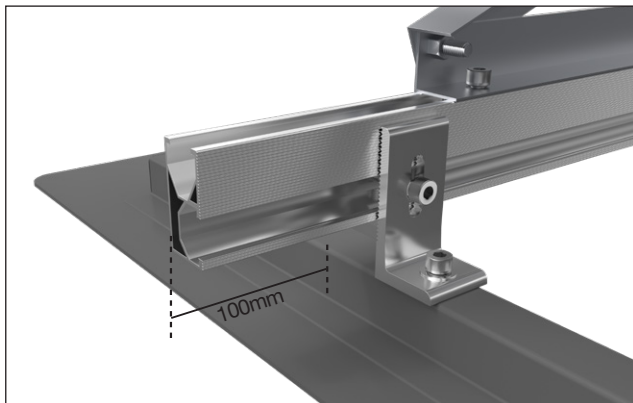

Figure 3

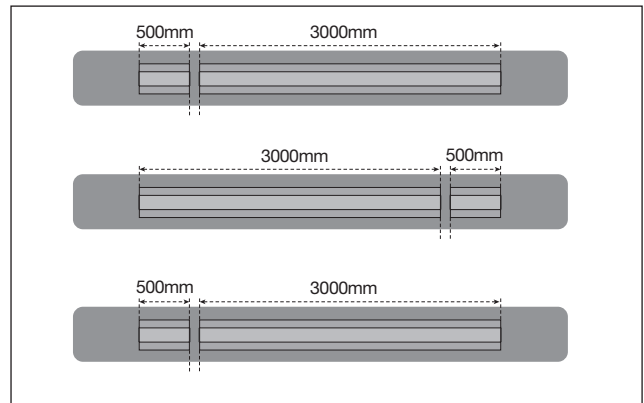

Figure 4

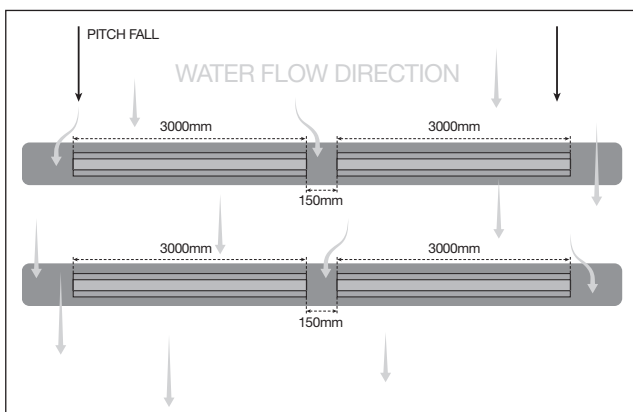

Figure 5

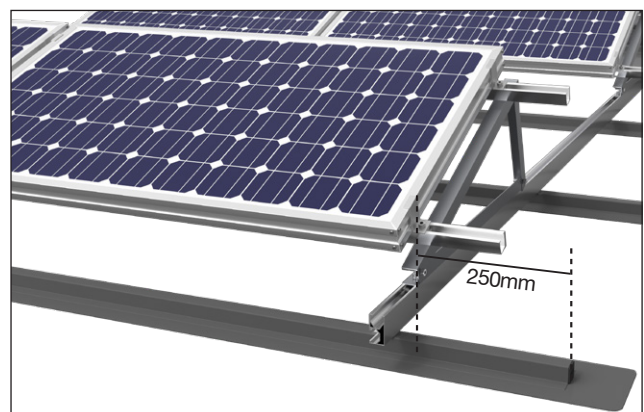

Figure 6

Legal Conditions

1. Compatibility of EJObar PVC and roofing membrane must be verified and the material properties of the respective aged membrane must also be considered.
2. An assessment must be conducted to ensure the load-bearing capacities.
3. Technical consultation with an EJOT specialist must be obtained prior to using the product.
4. The intended use is for the installation of solar components.
5. The installation guide must be observed.

Non-loadbearing applications

Short stand-alone pieces of EJObar < 1m are not permitted, the only exception being where the EJObar is used as a fixing base for non-structural elements e.g. cable gutters and similar rooftop ancillaries. Contact EJOT Technical Teams for guidance.

Disclaimer

The information contained within this current document is given in good faith, with the intention of providing advisory guidance. It is based on current knowledge at the time of issue and may be subject to change without notice. This information does not absolve users in any way of their obligation to comply with existing regulations, patents, statutory or local rules, technical approvals or the generally accepted rules of the industry. The purchaser is solely responsible for the end user of the product having correct information. EJOT SE & Co. KG, or any of its subsidiaries, cannot be held liable as a result of any disregard of regulations or instructions. As it is impossible to take account of all material circumstances and detailed problems, it is necessary in such cases to contact the relevant EJOT Technical Departments who will assist you with advice based on the information provided and available knowledge. Our warranty covering quality and functional behaviour of materials presented or listed in the system, is only in respect of the EJObar and ancillary materials which have been manufactured, supplied or approved by us.

E & OE.



EJOT U.K. Limited,
Hurricane Close,
Sherburn Enterprise Park,
Sherburn-in-Elmet,
Leeds LS25 6PB.
United Kingdom

Tel: (+44) 1977 68 70 40
Email: salesUK@ejot.com

www.ejot.co.uk

Bringing it together