

# ANCHOR BOLT M6-M16

**General purpose heavy duty anchor.**

## FUNCTION

Application of the installation torque draws the anchor's cone into the thick-walled expansion sleeve. This causes the sleeve to be pressed against the sidewalls of the hole and develops tension resistance through friction.



Type AB

Type AS

Unique correct-set indicator washers



Uninstalled

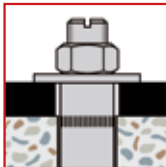

Installed

## BENEFITS

- Economical high capacity anchor
- Approved for use in cracked and non-cracked concrete.
- Torque indication from domed washer
- Custom lengths available on request
- Tested in accordance with ETA Option 1

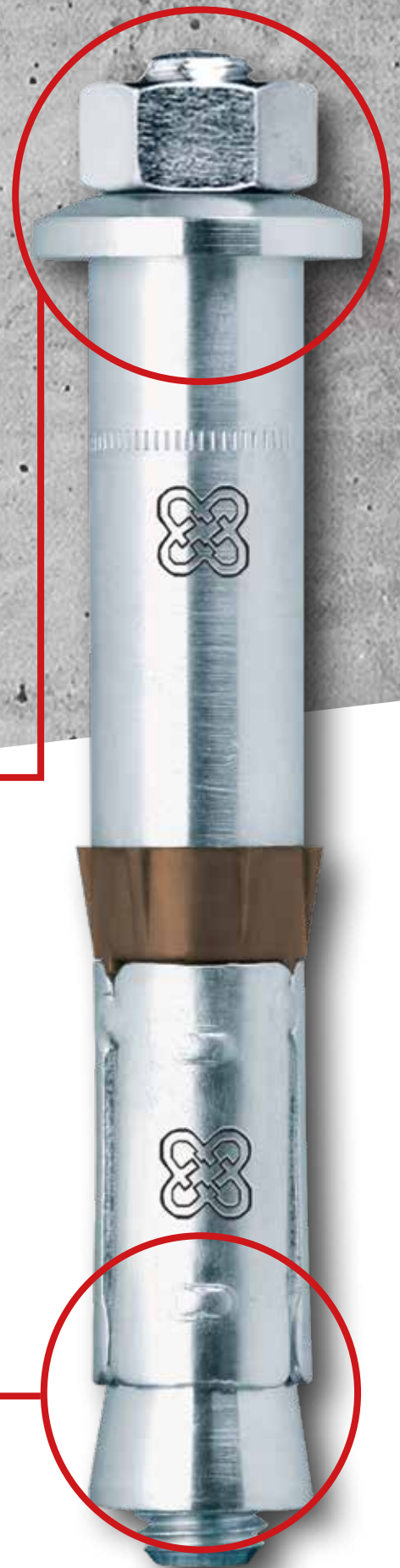

## CONSTRUCTION

**AB** With hex nut, domed washer and threaded stud



**AS** With hex head screw and domed washer



## MATERIAL

Grade 8.8 carbon steel, zinc plated

A4 stainless steel

## BASE MATERIAL

Cracked and non-cracked concrete: C20/25 to C50/60

## APPROVAL

ETA Option 1 – Carbon steel, zinc plated

## LOAD RANGE

Tension:  $N_{perm} = 2.4 - 37.2$  [kN]

Shear:  $V_{perm} = 5.2 - 54.9$  [kN]

## PRODUCT RANGE

**AB:** M6 - M16, carbon steel, zinc plated / A4 stainless steel

**AS:** M6 - M16, carbon steel, zinc plated / M6 - M12, A4 stainless steel

## APPLICATIONS

- Steel construction
- Cable trays
- Railing
- Machines
- Gates
- Façades
- Lifting systems
- Base plates

## BENEFITS

- Economical anchor for wide range of uses
- Torque indication from domed washer

## PRODUCT DESCRIPTION

- Heavy duty anchor for high loads
- Torque-controlled mechanical anchor



European technical approval option1

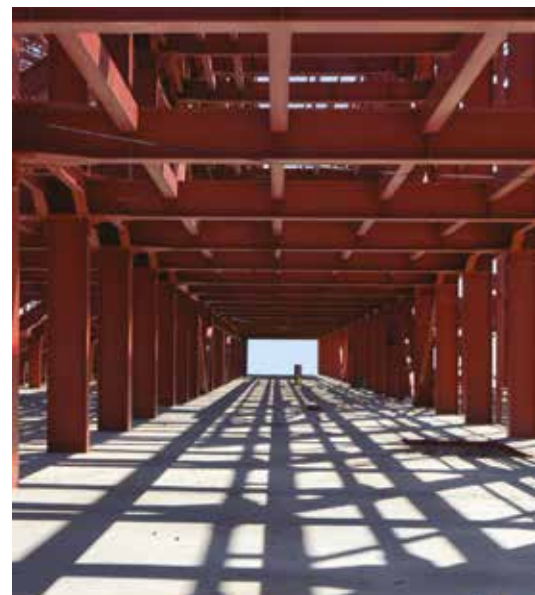

# ANCHOR BOLT M6-M16

Custom lengths available on request.

## ANCHOR AB, LAB Carbon Steel Zinc Plated

Threaded stud with hex nut and domed washer

Material: Grade 8.8 carbon steel, zinc plated

Approvals: ETA Option 1



New Type	Old Type	Order Code	Thread Size	Diameter x Depth of drilled hole	Max Fixture Thickness	Fixture Hole Diameter	Eff. Embedment Depth	Total Length	Weight (kg/100pcs)	Box Quantity
AB M6-10/45/5	AB 10/0	LAB0610045005	M6	10 x 60	5	12	45	70	2.7	50
AB M6-10/45/15	AB 10/15	LAB0610045015	M6	10 x 60	15	12	45	80	3.4	50
AB M6-10/45/40	AB 10/40	LAB0610045040	M6	10 x 60	40	12	45	105	4.6	50
AB M8-12/55/5	AB12/0	LAB0812055005	M8	12 x 70	5	14	55	85	5.8	25
AB M8-12/55/15	AB 12/15	LAB0812055015	M8	12 x 70	15	14	55	95	7.0	25
AB M8-12/55/40	AB 12/40	LAB0812055040	M8	12 x 70	40	14	55	120	9.0	25
AB M8-12/55/65	AB 12/65	LAB0812055065	M8	12 x 70	65	14	55	145	10.6	25
AB M8-12/55/100	-	LAB0812055100	M8	12 x 70	100	14	55	180	12.8	25
AB M10-15/65/5 AB	15/0	LAB1015065005	M10	15 x 85	5	17	65	100	11.0	25
AB M10-15/65/15	AB 15/15	LAB1015065015	M10	15 x 85	15	17	65	110	12.8	25
AB M10-15/65/40	AB 15/40	LAB1015065040	M10	15 x 85	40	17	65	135	16.0	10
AB M10-15/65/65	AB 15/65	LAB1015065065	M10	15 x 85	65	17	65	160	18.5	10
AB M10-15/65/100	-	LAB1015065100	M10	15 x 85	100	17	65	195	22.0	10
AB M12-20/80/5	AB 20/0	LAB1220080005	M12	20 x 100	5	21	80	120	20.8	10
AB M12-20/80/15	AB 20/15	LAB1220080015	M12	20 x 100	15	21	80	130	24.8	10
AB M12-20/80/40	AB 20/40	LAB1220080040	M12	20 x 100	40	21	80	155	29.0	10
AB M12-20/80/65	AB 20/65	LAB1220080065	M12	20 x 100	65	21	80	180	33.5	10
AB M12-20/80/100	-	LAB1220080100	M12	20 x 100	100	21	80	215	39.8	20
AB M16-25/100/5	AB 25/0	LAB1625100005	M16	25 x 125	5	26	100	150	43.4	5
AB M16-25/100/15	AB 25/15	LAB1625100015	M16	25 x 125	15	26	100	160	48.4	5
AB M16-25/100/40	AB 25/40	LAB1625100040	M16	25 x 125	40	26	100	185	56.7	5
AB M16-25/100/65	AB 25/65	LAB1625100065	M16	25 x 125	65	26	100	210	63.6	10
AB M16-25/100/100	-	LAB1625100100	M16	25 x 125	100	26	100	245	73.3	10

## ANCHOR AS Carbon Steel Zinc Plated

Hex head screw and domed washer

Material: Grade 8.8 carbon steel, zinc plated

Approval: ETA Option 1



New Type	Old Type	Order Code	Thread Size	Diameter x Depth of drilled hole	Max Fixture Thickness	Fixture Hole Diameter	Eff. Embedment Depth	Total Length	Weight (kg/100pcs)	Box Quantity
AS M6-10/45/5	AS 10/0	LAS0610045005	M6	10 x 60	5	12	45	70	2.7	50
AS M6-10/45/15	AS 10/15	LAS0610045015	M6	10 x 60	15	12	45	80	3.4	50
AS M6-10/45/40	AS 10/40	LAS0610045040	M6	10 x 60	40	12	45	105	4.6	50
AS M8-12/55/5	AS 12/0	LAS0812055005	M8	12 x 70	5	14	55	80	5.8	25
AS M8-12/55/15	AS 12/15	LAS0812055015	M8	12 x 70	15	14	55	90	7.0	25
AS M8-12/55/40	AS 12/40	LAS0812055040	M8	12 x 70	40	14	55	115	9.0	25
AS M10-15/65/5	AS 15/0	LAS1015065005	M10	15 x 85	5	17	65	95	11.0	25
AS M10-15/65/15	AS 15/15	LAS1015065015	M10	15 x 85	15	17	65	105	12.8	25
AS M10-15/65/40	AS 15/40	LAS1015065040	M10	15 x 85	40	17	65	130	16.0	10
AS M12-20/80/5	AS 20/0	LAS1220080005	M12	20 x 100	5	21	80	113	20.8	10
AS M12-20/80/15	AS 20/15	LAS1220080015	M12	20 x 100	15	21	80	123	24.8	10
AS M12-20/80/40	AS 20/40	LAS1220080040	M12	20 x 100	40	21	80	148	29.0	10
AS M16-25/100/15	AS 25/15	LAS1625100015	M16	25 x 125	15	26	100	155	48.4	5
AS M16-25/100/40	AS 25/40	LAS1625100040	M16	25 x 125	40	26	100	180	56.7	5

## TECHNICAL DATA Carbon Steel Zinc Plated

Permissible loads for single anchors with no influencing edge distances or spacings. Loads are calculated using partial safety factors from ETAG 001 and the characteristic anchor and installation data from this catalogue. Design calculations shall follow the requirements of ETA-06/0123.

Material: Carbon steel, Grade 8.8, zinc plated

Thread Size	M6	M8	M10	M12	M16
Effective embedment depth ( $h_{ef}$ ) (mm)	45	55	65	80	100
Type AB..., AS...	M6-10/45/...	M8-12/55/...	M10-15/65/...	M12-20/80/...	M16-25/100/...

### Permissible tension loads<sup>1)</sup>

$N_{perm}$	Concrete	Type	[kN]	M6		M8		M10		M12		M16	
				Cracked	Non-Cracked <sup>3)</sup>	Cracked	Non-Cracked <sup>3)</sup>	Cracked	Non-Cracked <sup>3)</sup>	Cracked	Non-Cracked <sup>3)</sup>	Cracked	Non-Cracked <sup>3)</sup>
	Cracked	C20/25	[kN]	2.4	3.6	7.6	12.3	17.1					
		C30/37	[kN]	2.9	4.4	9.3	15.0	20.9					
		C40/50	[kN]	3.4	5.0	10.7	17.3	24.2					
		C50/60	[kN]	3.7	5.5	11.8	19.0	26.6					
	Non-Cracked	C20/25	[kN]	3.0	4.8	9.5	17.1	24.0					
		C30/37	[kN]	3.6	5.8	11.6	20.9	29.3					
		C40/50	[kN]	4.2	6.7	13.4	24.2	33.8					
		C50/60	[kN]	4.6	7.4	14.8	26.6	37.2					

### Permissible shear loads<sup>1) 2)</sup>

$V_{perm}$	Concrete	Type	[kN]	M6		M8		M10		M12		M16	
				Cracked	Non-Cracked <sup>3)</sup>	Cracked	Non-Cracked <sup>3)</sup>	Cracked	Non-Cracked <sup>3)</sup>	Cracked	Non-Cracked <sup>3)</sup>	Cracked	Non-Cracked <sup>3)</sup>
	Cracked	C20/25	[kN]	5.2	7.0	18.0	24.5	34.3					
		C30/37	[kN]	6.3	8.5	21.9	29.8	41.7					
		C40/50	[kN]	7.3	9.9	22.3	34.3	48.5					
		C50/60	[kN]	8.0	10.8	22.3	34.3	53.1					
	Non-Cracked	C20/25	[kN]	7.2	9.8	22.3	34.3	48.0					
		C30/37	[kN]	8.6	11.9	22.3	34.3	54.9					
		C40/50	[kN]	8.6	13.8	22.3	34.3	54.9					
		C50/60	[kN]	8.6	14.3	22.3	34.3	54.9					

### Permissible bending moments<sup>1) 5)</sup>

$M_{perm}$ <sup>4)</sup>	[Nm]	M6	M8	M10	M12	M16
		6.9	17.1	34.3	60	152

### Spacings, edge distances and member thicknesses

Parameter	Symbol	Unit	M6	M8	M10	M12	M16
Effective embedment depth	$h_{ef}$	[mm]	45	55	65	80	100
Characteristic spacing <sup>5)</sup>	$s_{cr,N}$	[mm]	135	165	195	240	300
Minimum spacing	$s_{min}$	[mm]	60	80	130	200	300
Characteristic edge distance <sup>6)</sup>	$c_{cr,N}$	[mm]	67.5	82.5	97.5	120	150
Minimum edge distance	$c_{min}$	[mm]	80	100	130	200	300
Minimum member thickness	$h_{min}$	[mm]	100	110	130	160	200

### Installation data

Parameter	Symbol	Unit	M6	M8	M10	M12	M16	
Drill hole diameter	$d_0$	[mm]	10	12	15	20	25	
Drill hole depth	$h_1$	[mm]	60	70	85	100	125	
Clearance hole in the fixture	Through-fix anchorage	$d_f$	[mm]	12	14	17	21	26
	Installation on threaded stud	$d_f$	[mm]	7	9	12	14	18
Width across flat	AB	sw	[mm]	10	13	17	19	24
	AS	sw	[mm]	10	13	17	19	24
Installation torque	AB	$T_{inst}$	[Nm]	7	15	30	50	115
	AS	$T_{inst}$	[Nm]	8	20	50	75	170

### Installed anchor

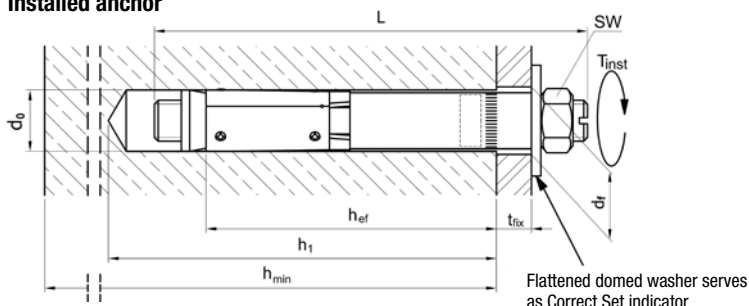

- 1) The permissible loads have been calculated using the partial safety factors for resistances stated in the ETA-approval and a partial safety factor for actions of  $\gamma_F = 1.4$ . The permissible loads are valid for unreinforced concrete and reinforced concrete with a rebar spacing  $s \geq 15$  cm and reinforced concrete with a rebar spacing  $s \geq 10$  cm if the rebar is 10 mm or smaller.
- 2) The permissible shear loads are based on a single anchor without influencing concrete edges. For shear loads applied close to an edge ( $c \leq 10 h_{ef}$  or  $60d$ ) concrete edge failure must be checked per ETAG 001, Annex C, design method A.
- 3) Concrete is considered non-cracked when the tensile stress within the concrete is  $\sigma_t + \sigma_{cr} \leq 0$ . In the absence of detailed verification  $\sigma_{cr} = 3$  N/mm<sup>2</sup> can be assumed ( $\sigma_t$  equals the tensile stress within the concrete as a result of external loads, forces on anchors included).
- 4) The permissible bending moments are only valid for the threaded stud type AB (e.g. in case of a distance mounting).
- 5) For spacings smaller than the characteristic values (i.e.  $s \leq s_{cr,N}$ ) a calculation per ETAG 001, Annex C, design method A shall be performed.
- 6) The actual edge distance shall not be less than the value of  $c_{min}$  shown in the table.

Custom lengths available on request.

## ANCHOR AB A4 stainless steel

Threaded stud with hex nut and domed washer  
Material: A4 stainless steel



New Type	Old Type	Order Code	Thread Size	Diameter x Depth of drilled hole	Max Fixture Thickness	Fixture Hole Diameter	Eff. Embedment Depth	Total Length	Weight (kg/100pcs)	Box Quantity
AB M6-10/45/5 A4	AB 10/0 A4	AB0610045005A4	M6	10 x 60	5	12	45	70	2.9	50
AB M6-10/45/15 A4	AB 10/15 A4	AB0610045015A4	M6	10 x 60	15	12	45	80	3.4	50
AB M6-10/45/40 A4	AB 10/40 A4	AB0610045040A4	M6	10 x 60	40	12	45	105	4.6	50
AB M8-12/55/5 A4	AB 12/0 A4	AB0812055005A4	M8	12 x 70	5	14	55	85	6.2	25
AB M8-12/55/15 A4	AB 12/15 A4	AB0812055015A4	M8	12 x 70	15	14	55	95	7.0	25
AB M8-12/55/40 A4	AB 12/40 A4	AB0812055040A4	M8	12 x 70	40	14	55	120	9.0	25
AB M10-15/65/5 A4	AB 15/0 A4	AB1015070005A4	M10	15 x 85	5	17	65	100	11.5	25
AB M10-15/65/15 A4	AB 15/15 A4	AB1015070015A4	M10	15 x 85	15	17	65	110	12.8	25
AB M10-15/65/40 A4	AB 15/40 A4	AB1015070040A4	M10	15 x 85	40	17	65	135	16.0	10
AB M12-20/80/5 A4	AB 20/0 A4	AB1220080005A4	M12	20 x 95	5	21	80	120	25.1	10
AB M12-20/80/15 A4	AB 20/15 A4	AB1220080015A4	M12	20 x 95	15	21	80	130	24.8	10
AB M12-20/80/40 A4	AB 20/40 A4	AB1220080040A4	M12	20 x 95	40	21	80	155	29.0	10
AB M16-25/100/15 A4	AB 25/15 A4	AB1625100015A4	M16	25 x 125	15	26	100	160	48.4	5
AB M16-25/100/40 A4	AB 25/40 A4	AB1625100040A4	M16	25 x 125	40	26	100	185	56.7	5

## ANCHOR AS A4 stainless steel

Hex head screw and domed washer  
Material: A4 stainless steel



New Type	Old Type	Order Code	Thread Size	Diameter x Depth of drilled hole	Max Fixture Thickness	Fixture Hole Diameter	Eff. Embedment Depth	Total Length	Weight (kg/100pcs)	Box Quantity
AS M6-10/45/5 A4	AS 10/0 A4	AS0610045005A4	M6	10 x 60	5	12	45	70	2.9	50
AS M6-10/45/15 A4	AS 10/15 A4	AS0610045015A4	M6	10 x 60	15	12	45	80	3.4	50
AS M8-12/55/15 A4	AS 12/15 A4	AS0812055015A4	M8	12 x 70	15	14	55	90	7.0	25
AS M8-12/55/40 A4	AS 12/40 A4	AS0812055040A4	M8	12 x 70	40	14	55	115	9.0	25
AS M10-15/65/15 A4	AS 15/15 A4	AS1015065015A4	M10	15 x 85	15	17	65	105	12.8	25
AS M10-15/65/40 A4	AS 15/40 A4	AS1015065040A4	M10	15 x 85	40	17	65	130	16.0	10
AS M12-20/80/15 A4	AS 20/15 A4	AS1220080015A4	M12	20 x 95	15	21	80	123	24.8	10
AS M12-20/80/40 A4	AS 20/40 A4	AS1220080040A4	M12	20 x 95	40	21	80	148	29.0	10

## TECHNICAL DATA A4 stainless steel

Permissible loads for single anchors with no influencing edge distances or spacings. Loads are calculated using partial safety factors from ETAG 001 and the characteristic anchor and installation data from this catalogue.

Material: A4 Stainless steel

Thread Size	M6	M8	M10	M12	M16
Effective embedment depth ( $h_{ef}$ ) (mm)	45	55	65	80	100
Type AB..., AS...	M6-10/45/...	M8-12/55/...	M10-15/65/...	M12-20/80/...	M16-25/100/...

### Permissible tension loads<sup>1)</sup>

$N_{perm}$							
			M6	M8	M10	M12	M16
	Cracked Concrete	C20/25 [kN]	-	-	-	7.1	10.7
		C30/37 [kN]	-	-	-	8.4	12.6
		C40/50 [kN]	-	-	-	9.5	14.3
		C50/60 [kN]	-	-	-	10.5	15.8
	Non-Cracked Concrete <sup>3)</sup>	C20/25 [kN]	3.2	4.3	7.1	10.7	16.0
		C30/37 [kN]	3.9	5.2	8.6	12.6	18.8
		C40/50 [kN]	4.5	6.1	10.0	14.3	21.4
		C50/60 [kN]	5.0	6.7	11.0	15.8	23.7

### Permissible shear loads<sup>1) 2)</sup>

$V_{perm}$										
			M6	M8	M10	M12	M16	AB	AS	AB
	Cracked Concrete	C20/25 [kN]	-	-	-	20.5	20.5	28.6	28.6	
		C30/37 [kN]	-	-	-	24.2	24.2	33.7	33.7	
		C40/50 [kN]	-	-	-	27.5	24.6	38.3	38.3	
		C50/60 [kN]	-	-	-	28.9	24.6	42.3	41.5	
	Non-Cracked Concrete <sup>3)</sup>	C20/25 [kN]	3.2	4.3	7.1	28.7	24.6	40.0	40.0	
		C30/37 [kN]	3.9	5.2	8.6	28.9	24.6	47.2	41.5	
		C40/50 [kN]	4.5	6.1	10.0	28.9	24.6	49.5	41.5	
		C50/60 [kN]	5.0	6.7	11.0	28.9	24.6	49.5	41.5	

### Permissible bending moments<sup>1) 4)</sup>

$M_{perm}$ <sup>4)</sup>	[Nm]	M6	M8	M10	M12	M16
		6.5	16.1	32.1	56.1	142.7

### Spacings, edge distances and member thicknesses

		M6	M8	M10	M12	M16
Effective embedment depth	$h_{ef}$ [mm]	45	55	70	80	100
Characteristic spacing <sup>5)</sup>	$s_{cr,N}$ [mm]	140	165	235	240	300
Minimum spacing	$s_{min}$ [mm]	140	165	235	80	100
Characteristic edge distance	$c_{cr,N}$ [mm]	80	120	165	120	150
Minimum edge distance <sup>6)</sup>	$c_{min}$ [mm]	80	120	165	160	200
Minimum member thickness	$h_{min}$ [mm]	100	110	130	150	200

### Installation data

		M6	M8	M10	M12	M16	
Drill hole diameter	$d_0$ [mm]	10	12	15	20	25	
Drill hole depth	$h_1$ [mm]	60	70	85	95	125	
Clearance hole in the fixture	Through-fix anchorage	$d_f$ [mm]	12	14	17	21	26
	Installation on threaded stud	$d_f$ [mm]	7	9	12	14	18
Width across flats	AB, AS sw [mm]	10	13	17	19	24	
Installation torque	AB, AS $T_{inst}$ [Nm]	10	25	50	80	180	

### Installed anchor

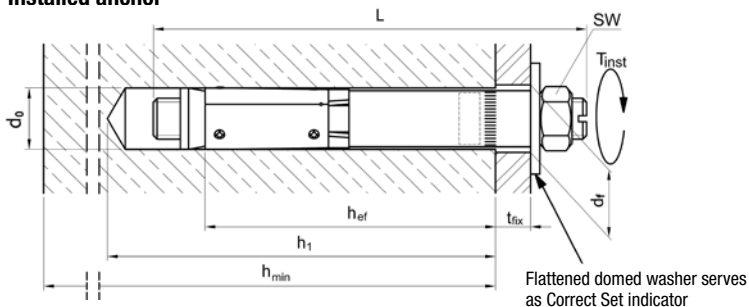

- 1) The permissible loads have been calculated using the partial safety factors for resistances stated in the ETA-approval and a partial safety factor for actions of  $\gamma_c = 1.4$ . The permissible loads are valid for unreinforced concrete and reinforced concrete with a rebar spacing  $s \geq 15$  cm and reinforced concrete with a rebar spacing  $s \geq 10$  cm if the rebar is 10 mm or smaller.
- 2) The permissible shear loads are based on a single anchor without influencing concrete edges. For shear loads applied close to an edge ( $c \leq 10 h_{ef}$  or  $60d$ ) concrete edge failure must be checked per ETAG 001, Annex C, design method A.
- 3) Concrete is considered non-cracked when the tensile stress within the concrete is  $\sigma_L + \sigma_R \leq 0$ . In the absence of detailed verification  $\sigma_R = 3$  N/mm<sup>2</sup> can be assumed ( $\sigma_L$  equals the tensile stress within the concrete as a result of external loads, forces on anchors included).
- 4) The permissible bending moments are only valid for the threaded stud type AB (e.g. in case of a distance mounting).
- 5) For spacings smaller than the characteristic values (i.e.  $s \leq s_{cr,N}$ ) a calculation per ETAG 001, Annex C, design method A shall be performed.
- 6) The actual edge distance shall not be less than the value of  $c_{min}$  shown in the table.



EJOT UK Limited,  
Hurricane Close,  
Sherburn Enterprise Park,  
Sherburn-in-Elmet,  
Leeds LS25 6PB.  
United Kingdom

**Tel: +44 1977 68 70 40**

**Fax: +44 1977 68 70 41**

**Email: [liebig@ejot.co.uk](mailto:liebig@ejot.co.uk)  
[info@ejot.co.uk](mailto:info@ejot.co.uk)**